

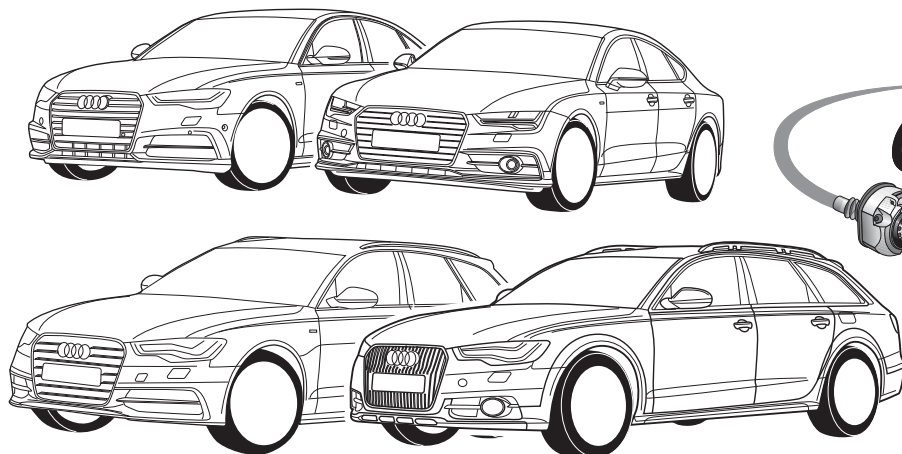

Right Connections...

SUPPLIERS OF TOWBAR WIRING KITS FOR THE UK



A6 Allroad Quattro	05/12 ->
A6 Avant	03/11 ->
A6 Saloon	03/11 ->
A7 Sportback	10/10 ->

Part No: AU-069-13

Electric wiring kit for towbars / 13-pin / 12 Volt / ISO 11446 **Fitting instructions**

All models with trailer preparation -> 05/2014

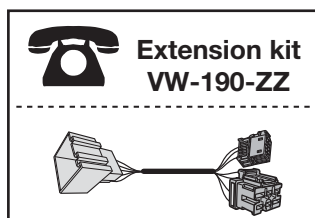
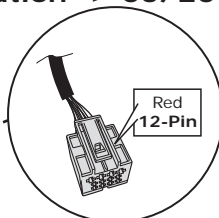
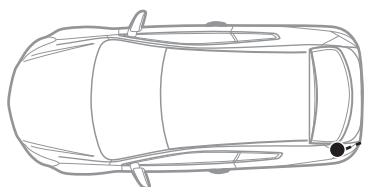

All models with trailer preparation 06/2014 ->

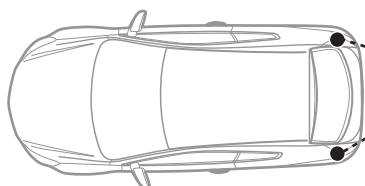

or

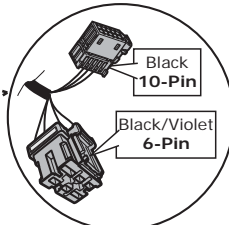

IMPORTANT!

This electric kit has to be installed by a professional workshop or a suitable qualified person.

The installation instructions must have been read and fully understood before the start of any installation. Please contact your wiring kit provider or the hotline shown in the footer should you need assistance!

Make sure the vehicle is approved/homologated by the manufacturer to tow a trailer!

Also please check that there is a definite compatibility between this vehicle and the electric kit!

Following the installation of the electric kit, the fitting instructions should be kept together with the vehicle service document and vehicle handbook. The fitting instructions contain important information relating to the use and function of the towing kit as well as for any diagnostic or activation process, that might have to be repeated in the future (e.g. after the performance of a vehicle software update).

All warranty claims will be forfeited if the electric kit or components contained therein are used incorrectly or modified. If a towing socket adaptor has been used to connect to the trailer or bike rack, this must be removed from the trailer socket once the trailer or bike rack has been disconnected.

If the trailer or bike rack is not equipped with a rear fog lamp, depending on the towing vehicle type, the correct function of the towing kit cannot be guaranteed. In such cases, a rear fog lamp should be retro fitted.

This towing electric kit will not be covered under warranty if any technical or electrical modifications or software updates have been performed by the vehicle manufacturer after the initial commissioning of the kit. That applies especially to modifications or updates which may cause malfunctions in the trailer socket or any other part of the trailer electrical equipment!

Depending on the type of trailer module used in this electric kit, diagnostic interrogation with the vehicle's electrical system may be limited or will not function. The error memory inside the trailer module may not be able to be accessed by vehicle manufacturers diagnostic system.

Error logs relating to the trailer electrical equipment, that may be generated in the vehicle manufacturers diagnostic system as a result of a test procedure, may be due to the incorrect installation of the towing electric kit or the false activation of the trailer module.

We always recommend whenever possible, the following troubleshooting process:

→ **An analysis of the vehicle's error memory and possibly clearing of all faults before the start of the installation!**

→ **Try disconnecting the trailer module from the towing harness and re-start the fault clearing process!**

→ **If in doubt, limit the time for troubleshooting to a max of 0,5 hours and call our Technical Support Team!**

Please follow our instructions carefully and always test the towing electrics using a true lighting board or a specifically designed bulb tester. If an LED tester is used, ensure it is equipped with correct load resistors or malfunctions will occur!

This instruction is subject to changes and we reserve the right to make changes to design, colour etc.

All of the data and illustrations may not be an exact representation but the text contained in this instruction must be observed!

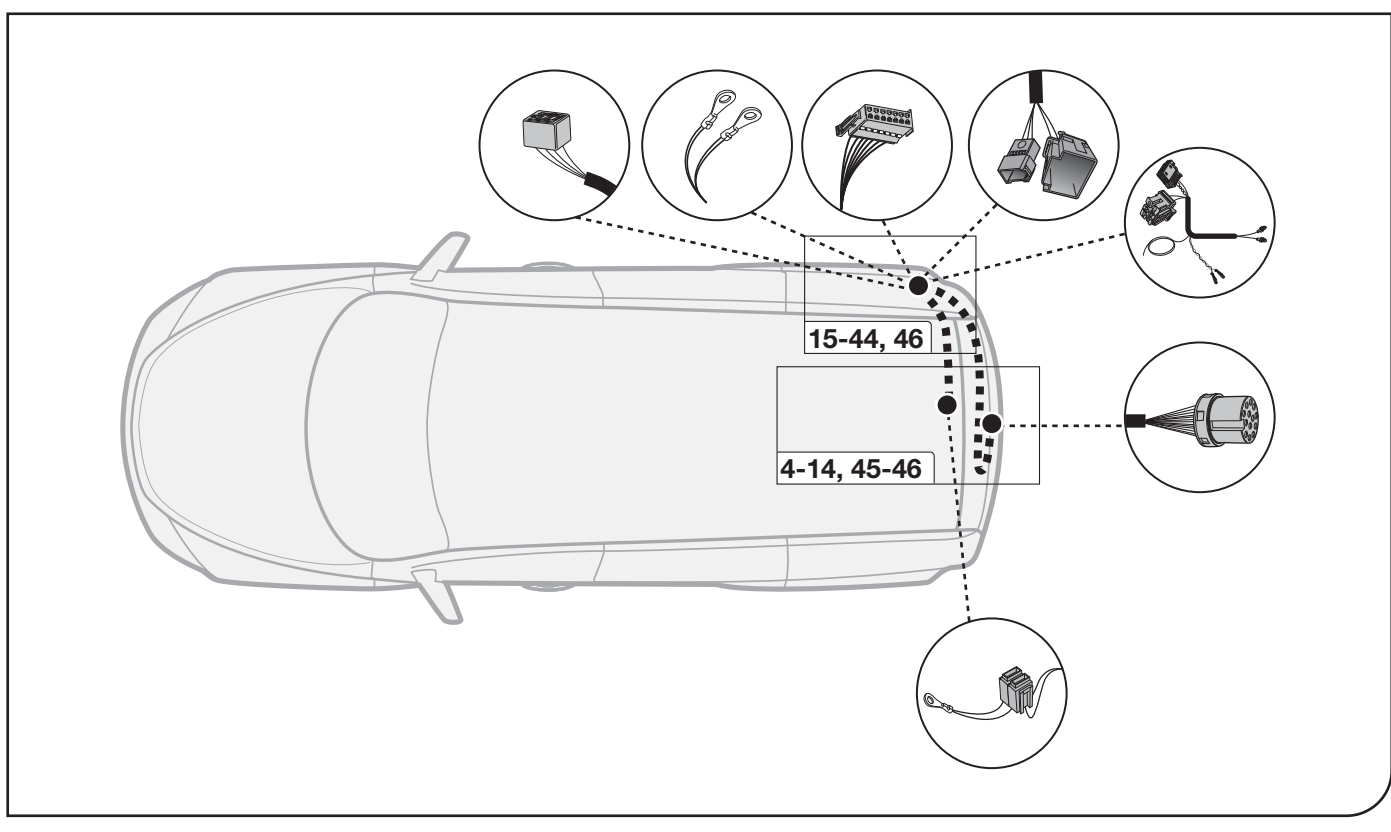
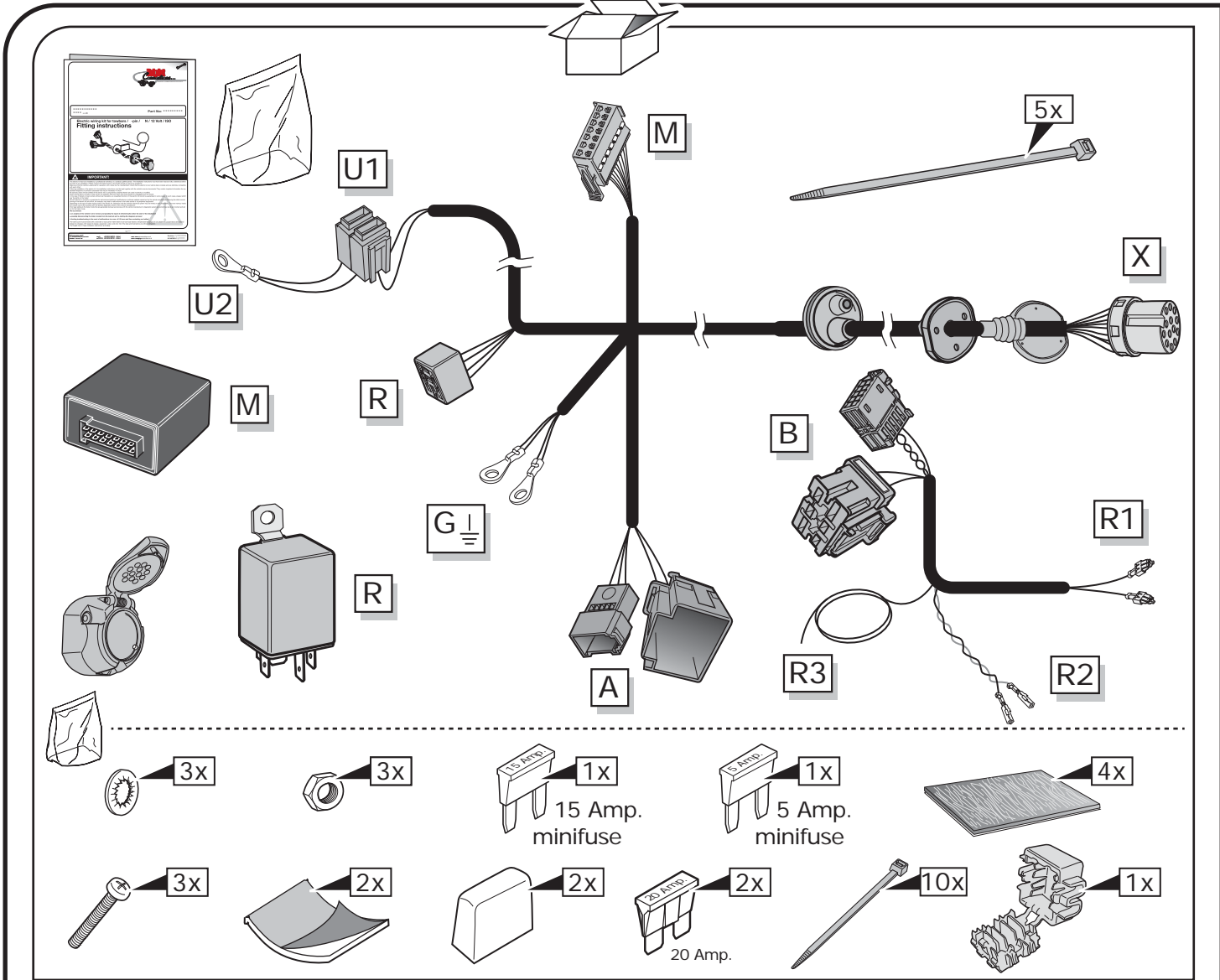

SYMBOL EXPLANATION

	Left (58-L) respectively Right (58-R) tail light
54	Stop light (54) / high mounted, third stop light (54)
	Turn signal indicator left
	Turn signal indicator right
	Rear fog light(s)
	Reversing light(s)
	Permanent power supply / 13pin socket, chamber 9
	Charging wire for trailer battery / 13pin socket, chamber 10
	Trailer / trailer recognition
B+ / 30	Permanent current power supply
	Ground or Earth (31)
	Ground connection battery terminal lug
	Positive connection battery terminal lug

	Cigarette lighter / accessory socket
	Loudspeaker / buzzer
	Park Distance Control
	Switch / source of function
	Connect together
	Disconnect
	Look at / See further information
	Look carefully at selected area
	Present / Occupied / OK
	Not present / Not occupied / Not OK
	Acoustic indication
	Attention / important advice
	Fuse / fuse capacity 20 Ampère

TOOLS

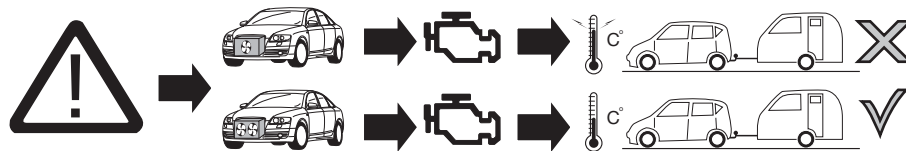
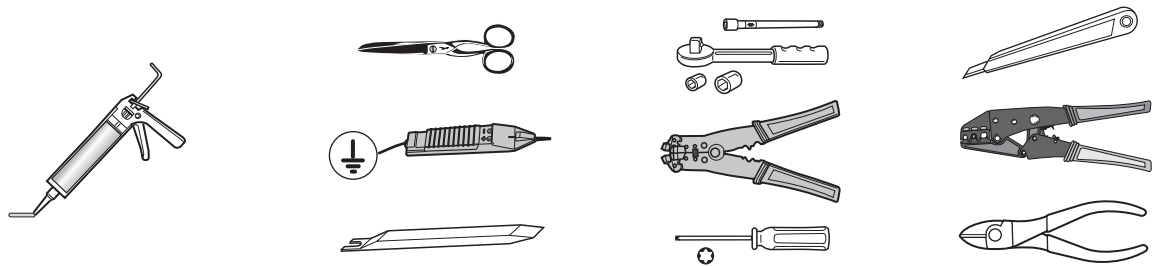

ATTENTION!

The vehicle's cooling capacity may have to be increased when retrofitting a trailer coupling!
You must observe the manufacturer's instructions!!

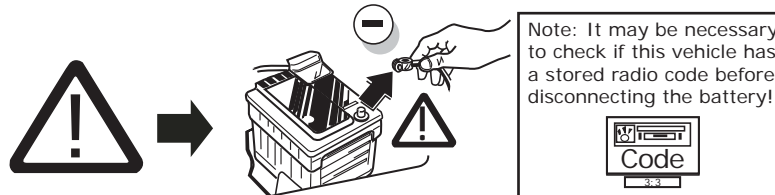

ATTENTION!

In order to avoid mal-functions and damage to the vehicle's electrical system the earth terminal **must be disconnected** from the vehicle's battery **before starting work!**

Both the trailer module and the vehicle's control unit for the electrical system can be damaged during work on the data bus connections if the battery is not disconnected!

1

Please pay attention to the manufacturer's instructions when disconnecting and reconnecting the vehicle's battery!

A6 Saloon/ A7 Sportback

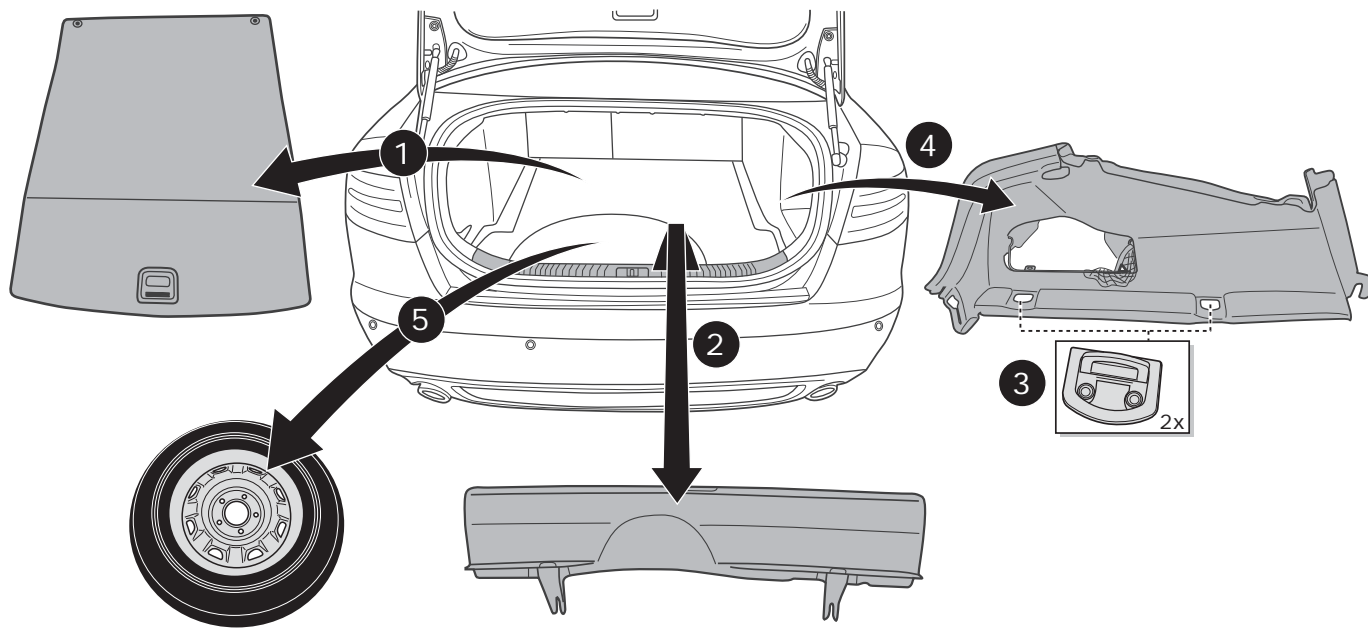

2

A6 Avant/ A6 Allroad Quattro

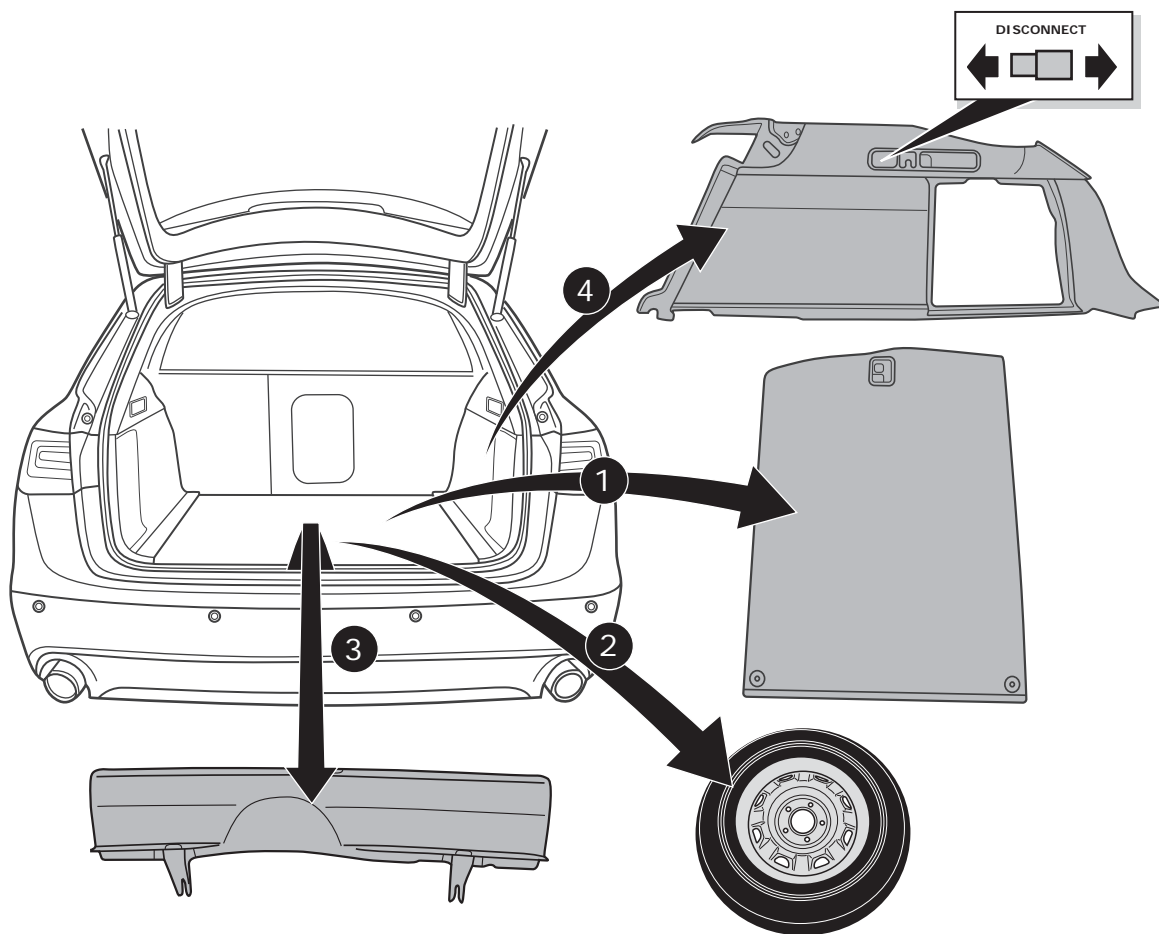

3

A6 Saloon/ A7 Sportback

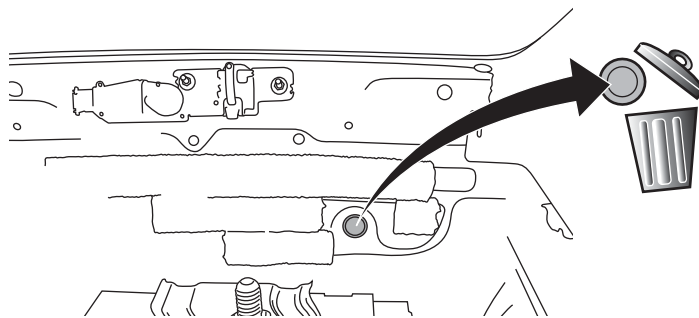
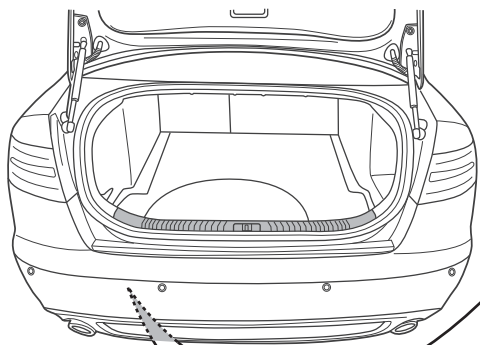

4

A6 Avant/ A6 Allroad Quattro

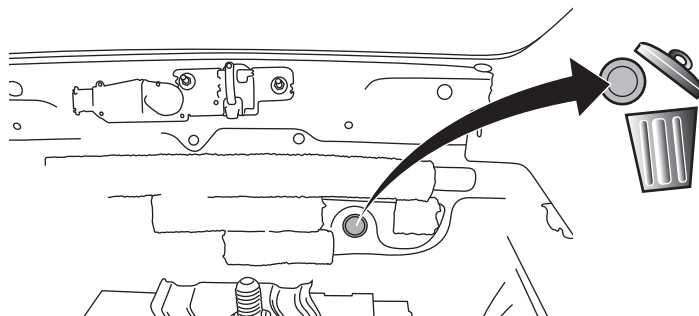
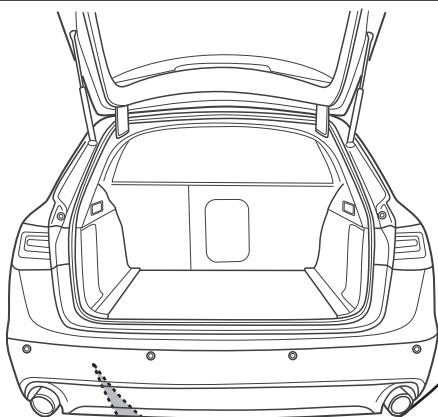

5

A6 Saloon/ A7 Sportback

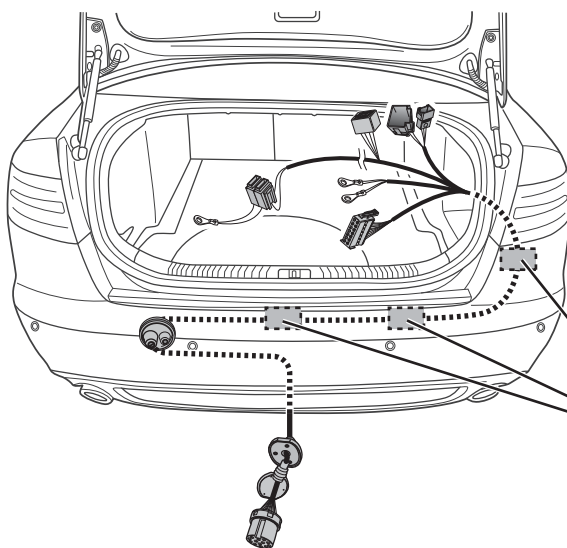

6

A6 Avant/ A6 Allroad Quattro

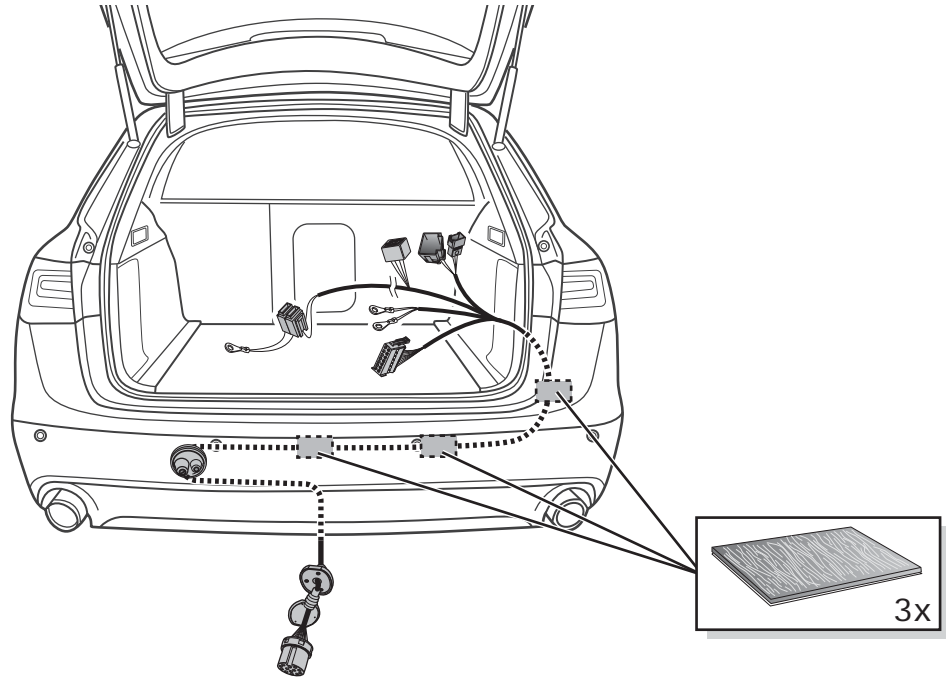

7

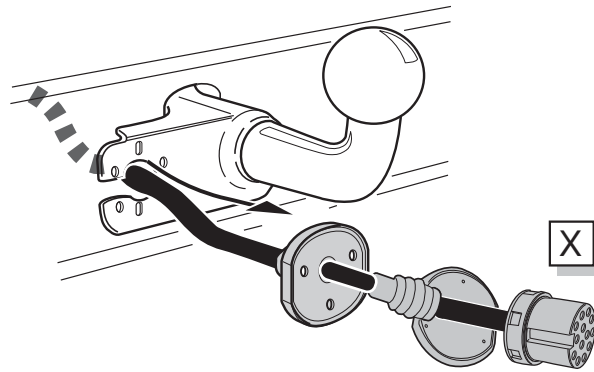

8

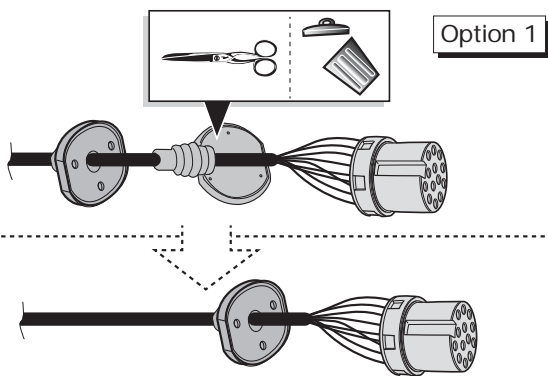

Option 2

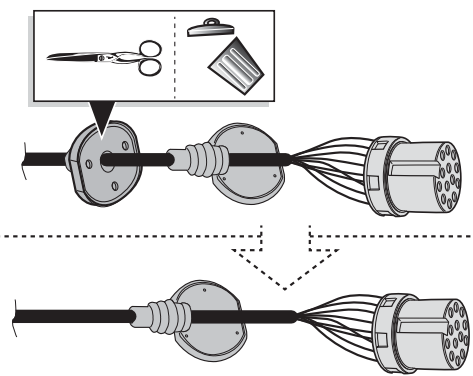

9

SOCKET CONNECTION

DIN/ISO 11446	↶ L	⊕	⚡ 1-8	↷ R	☀	⊖	☀	Reverse	30V	15V	⚡ 10	—	⚡ 9
	1/L	2	3/31	4/R	5/58-R	6/54	7/58-L	8	9	10	11	12	13
Pmax	21W	21W		21W	52W	3x21W	52W	21W	240W	180W			
Colour	Yellow	Blue	White	Green	Brown	Red	Black	Pink	Orange	Grey	White/Black	-	White/Red

10

Option 1

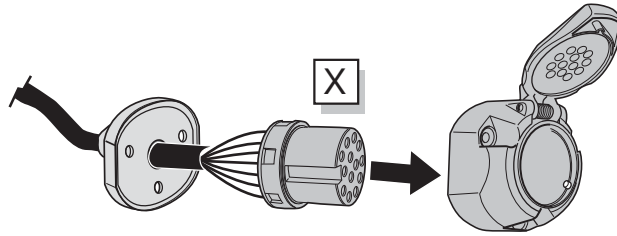

11

Option 1

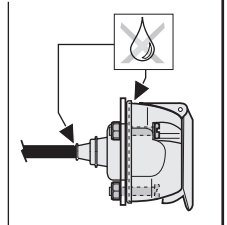
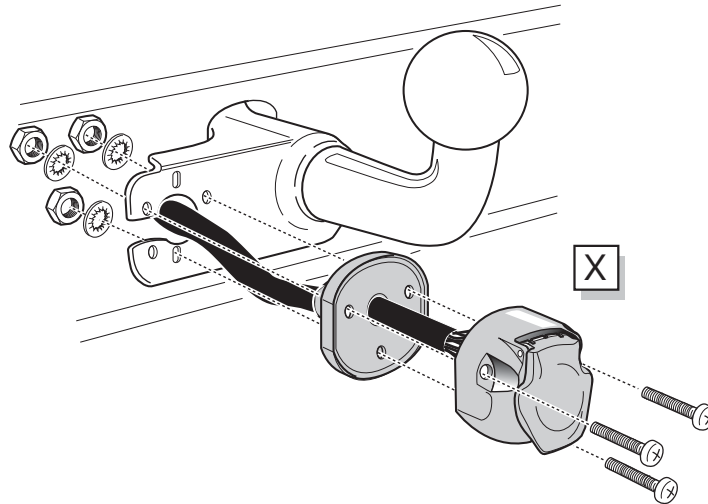

12

Option 2

1

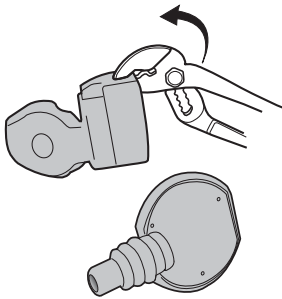

2

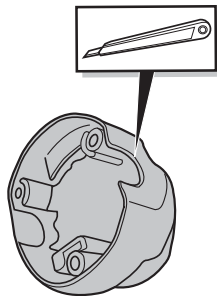

3

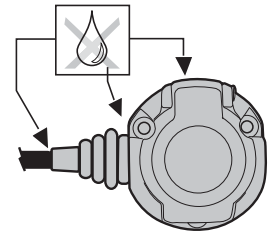
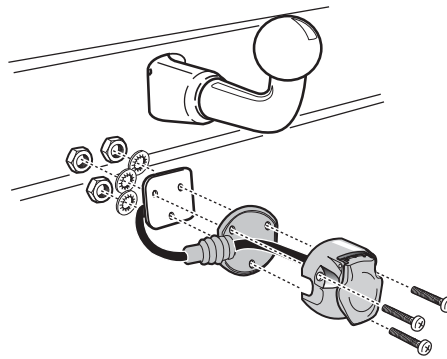

13

Option 2

1

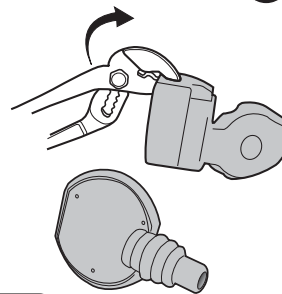

2

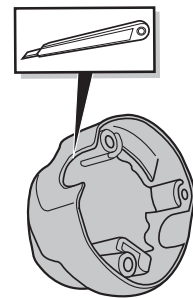

3

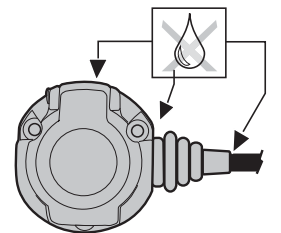
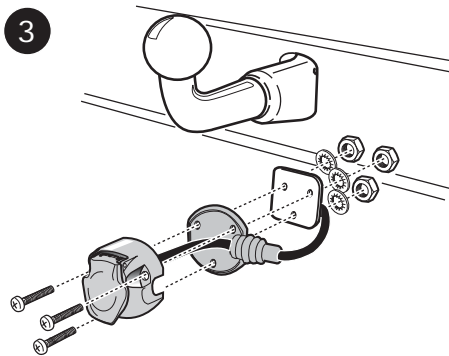

14

A6 Saloon/ A7 Sportback

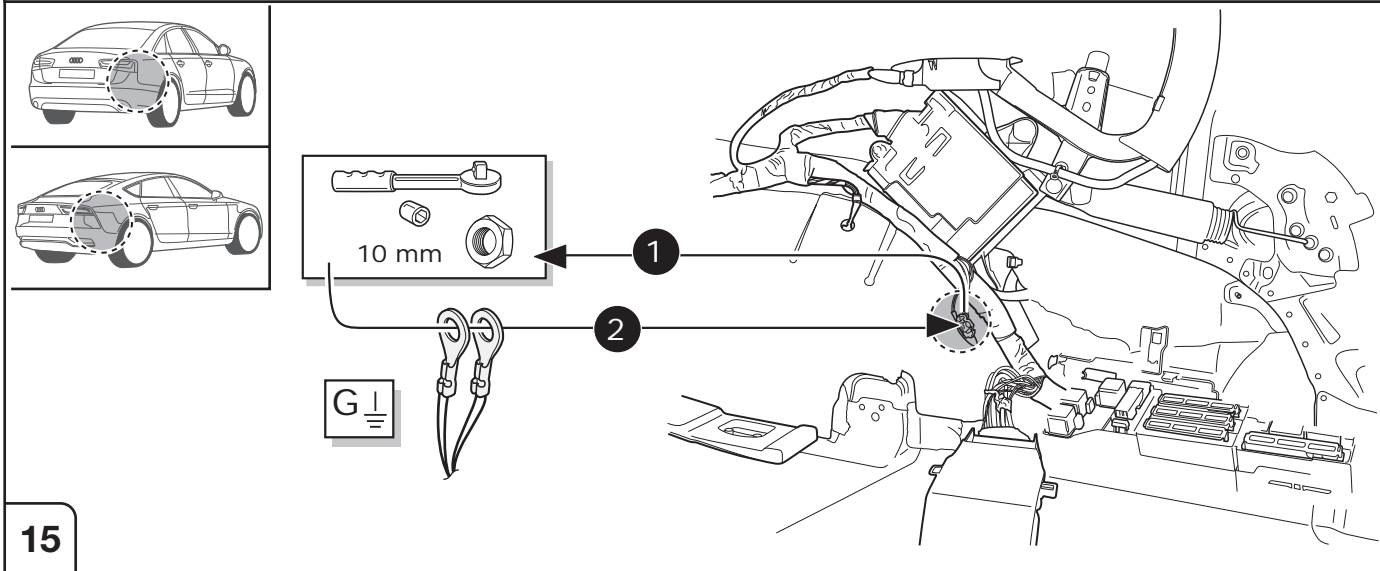

15

A6 Avant/ A6 Allroad Quattro

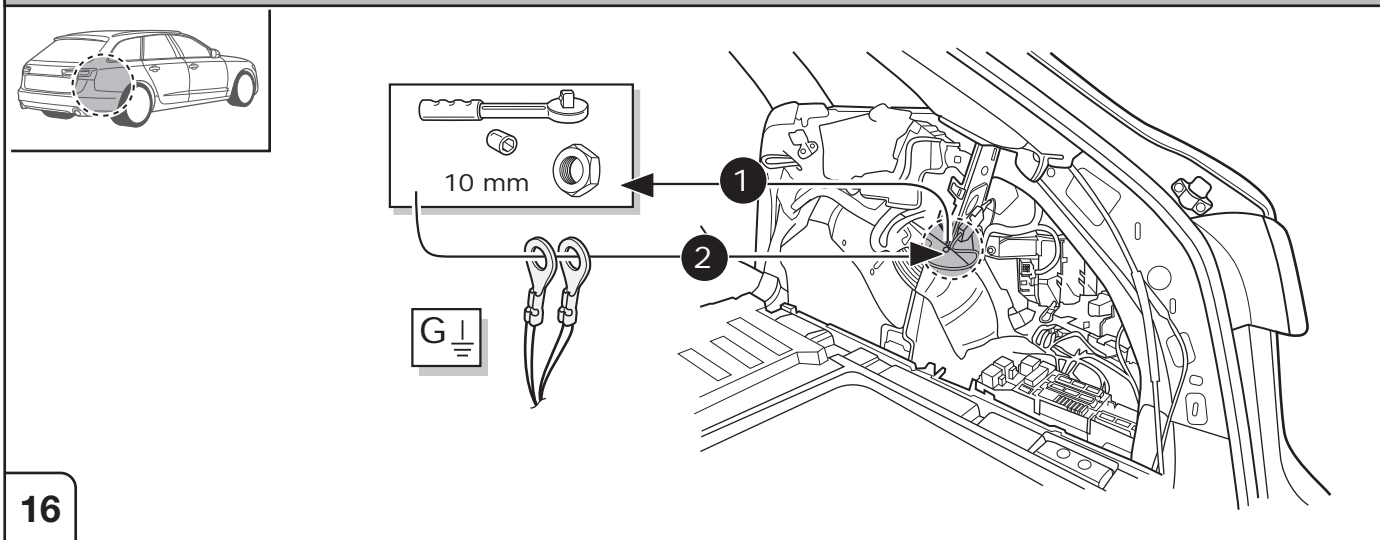

16

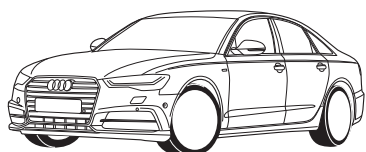

A6 Saloon

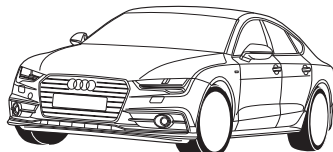

A7 Sportback



18	-	30
44	-	54

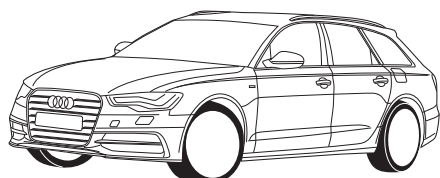

A6 Avant

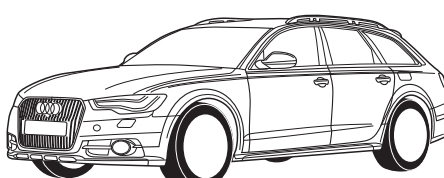

A6 Allroad Quattro



31	-	54
----	---	----

17

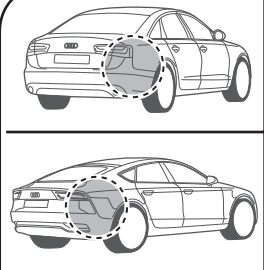

Option 1 Vehicles with trailer preparation

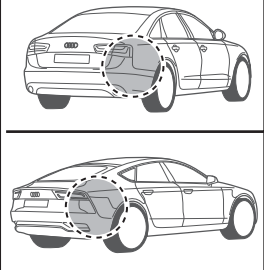
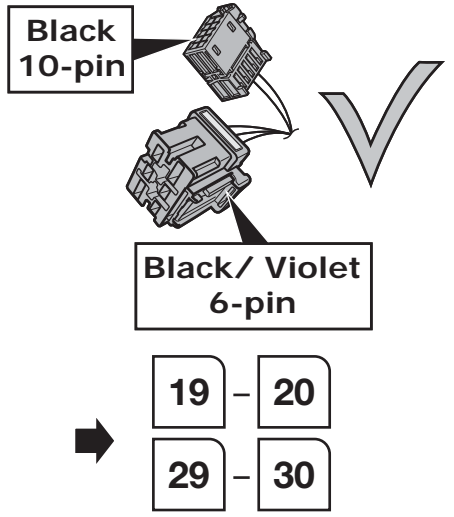
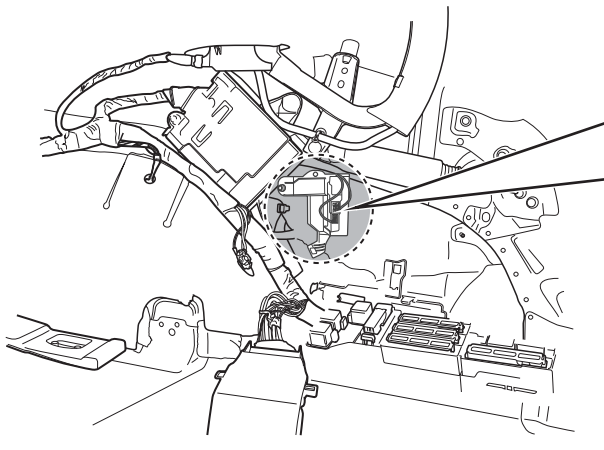

Option 2 Vehicles without trailer preparation

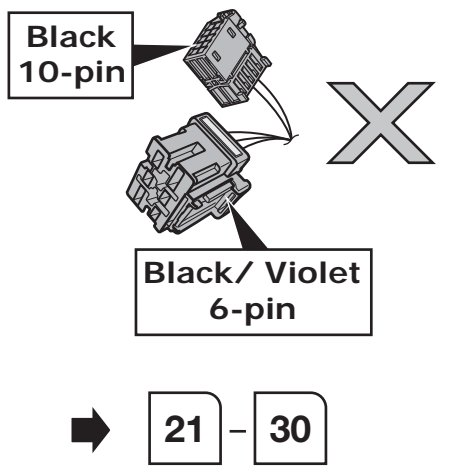
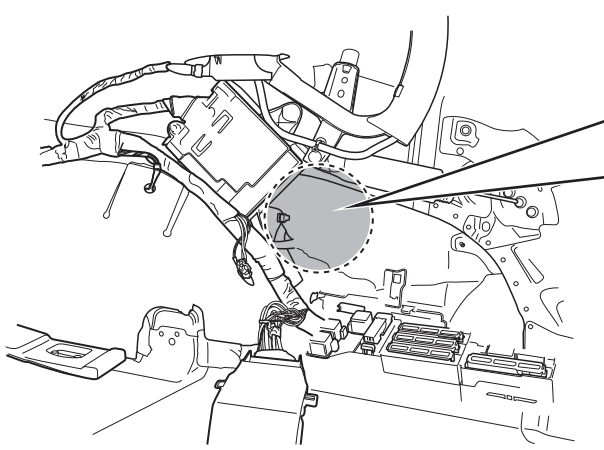

18

A6 Saloon/ A7 Sportback

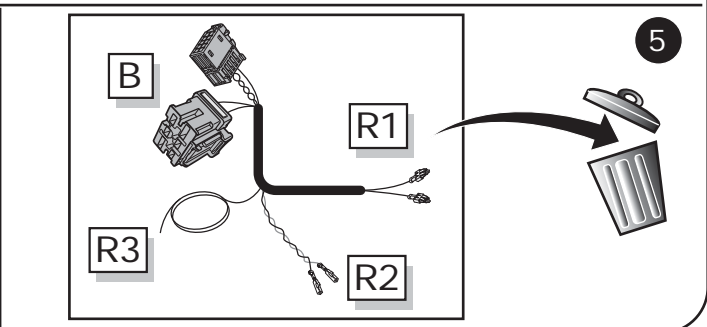
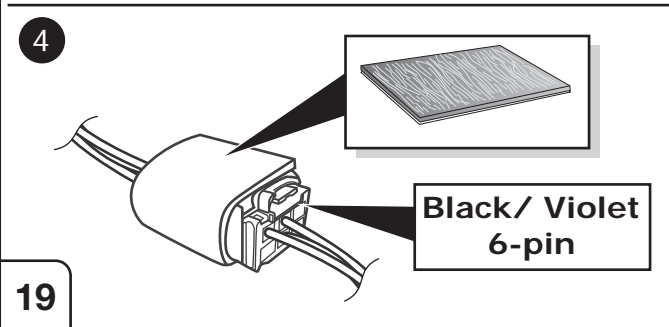
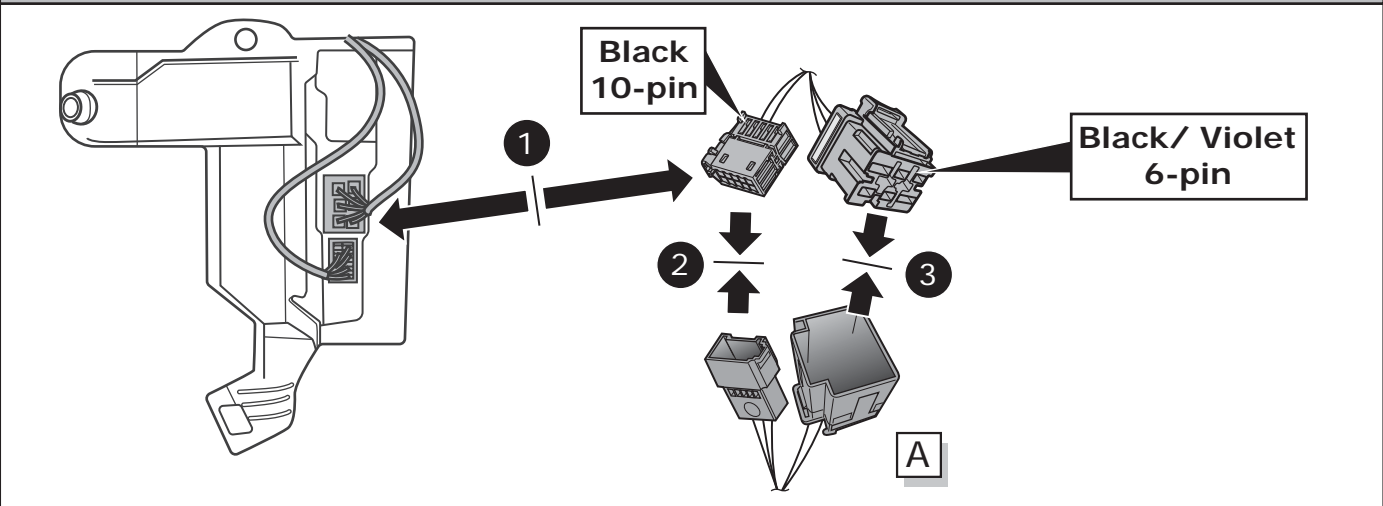

A6 Saloon/ A7 Sportback

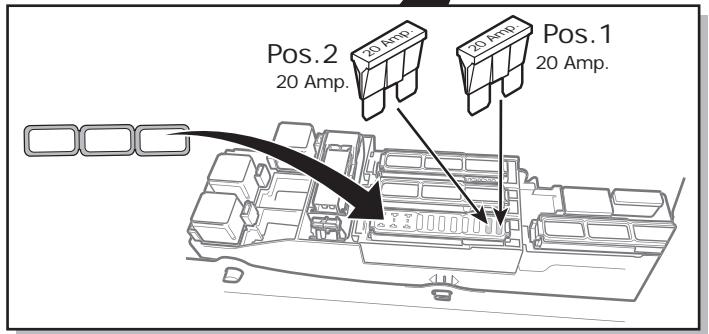
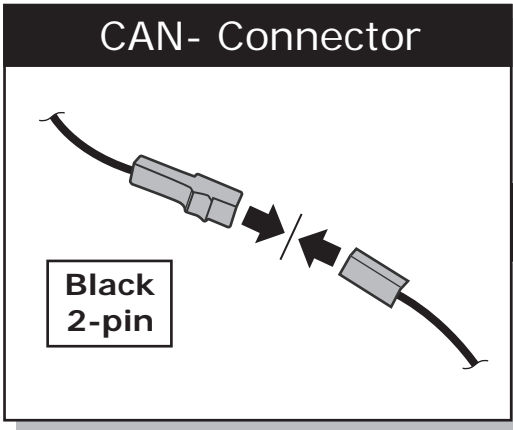
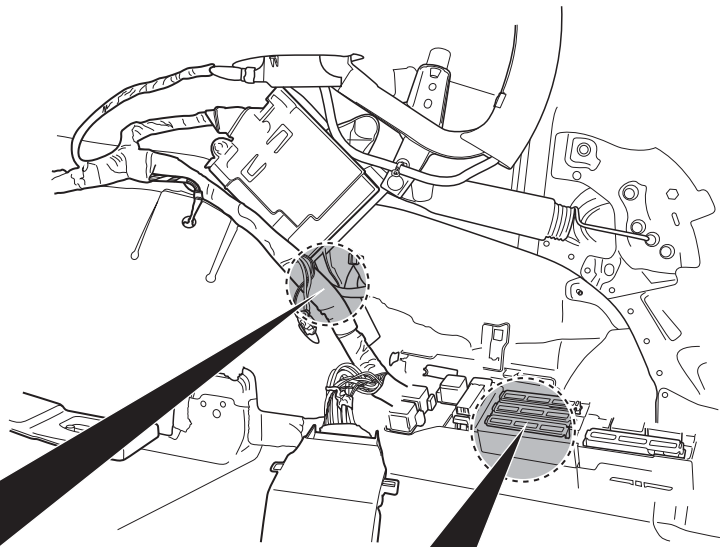
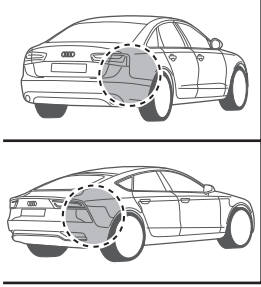

Important!
Please note informations in picture 1!

20

A6 Saloon/ A7 Sportback

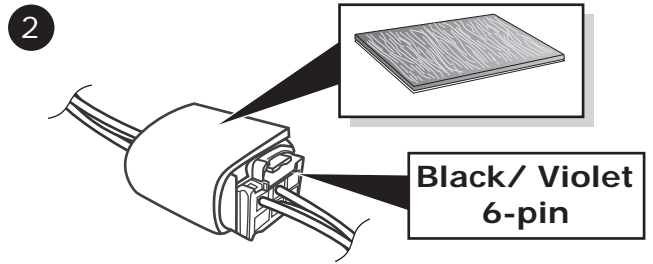
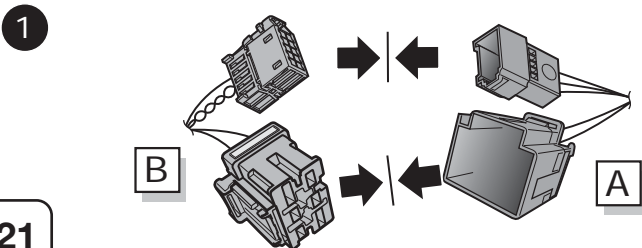

21

A6 Saloon/ A7 Sportback

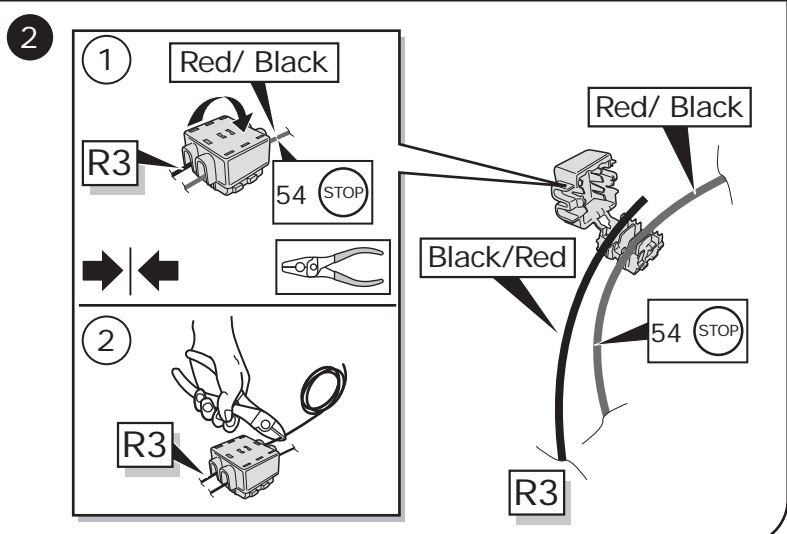
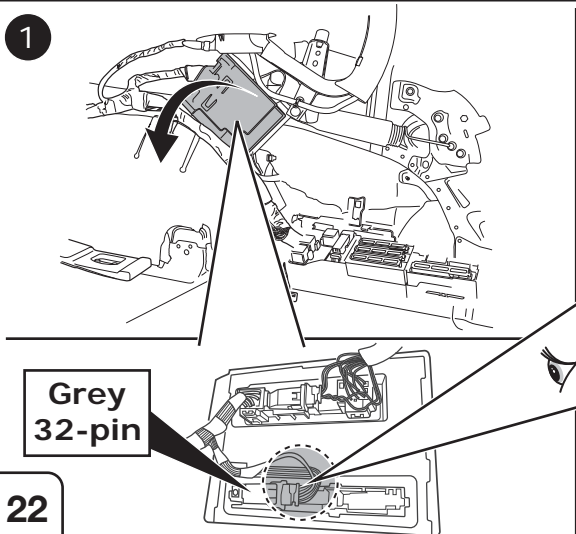

22

A6 Saloon/ A7 Sportback

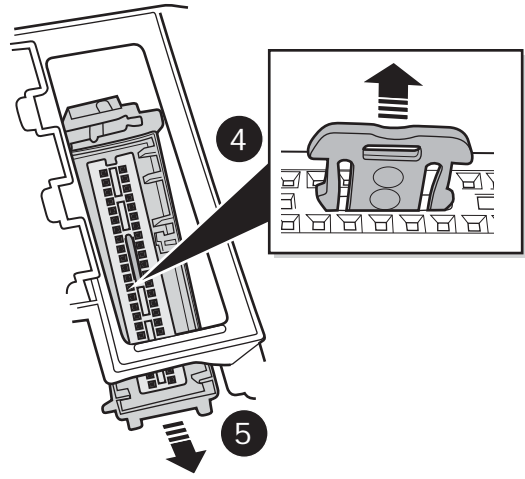
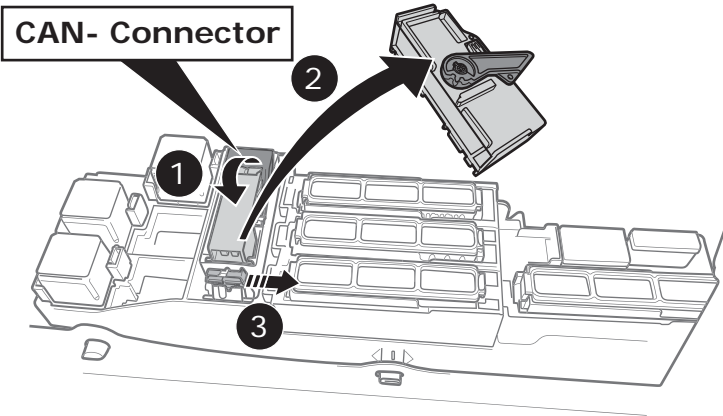

23

A6 Saloon/ A7 Sportback

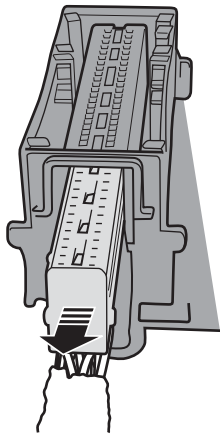

Locate empty chambers in array 1-8

Orange/ Green
Pos. 1-8H

Orange/ Brown
Pos. 1-8L

R2



Important!
Please note informations in picture 1!

24

A6 Saloon/ A7 Sportback

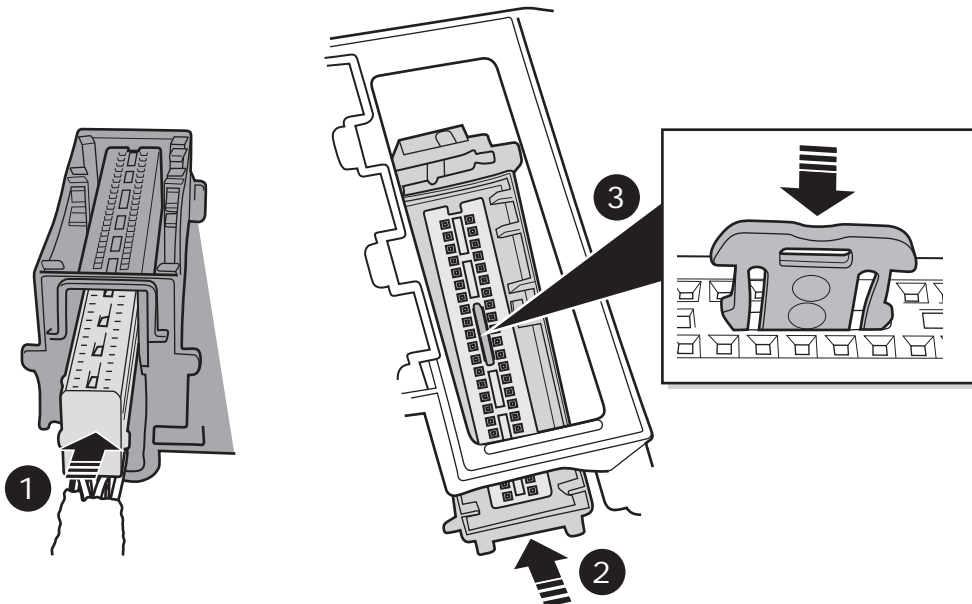

25

A6 Saloon/ A7 Sportback

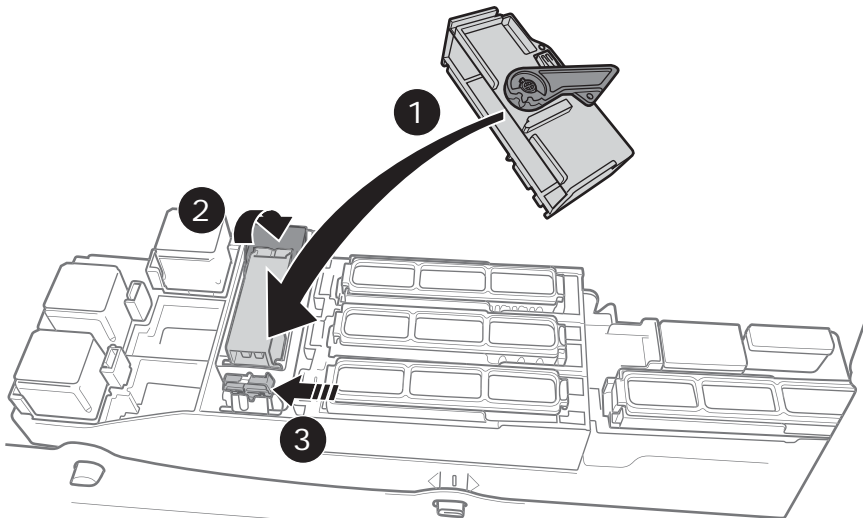

26

A6 Saloon/ A7 Sportback

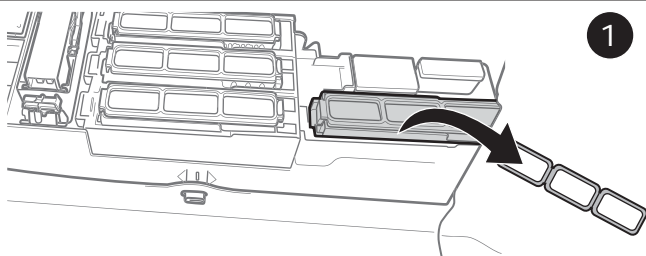

1

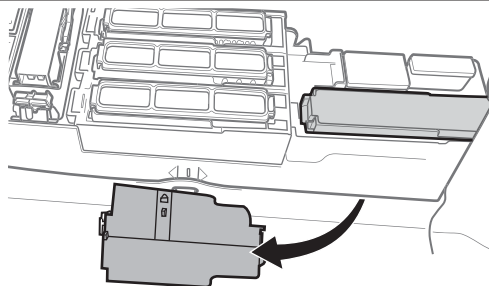

2

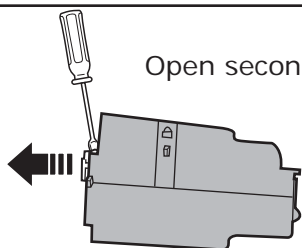

Open secondary lock!

3

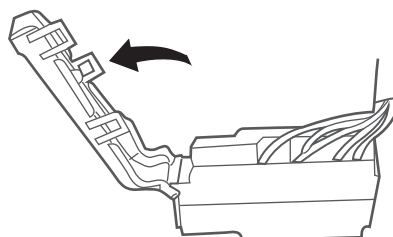

4

27

A6 Saloon/ A7 Sportback

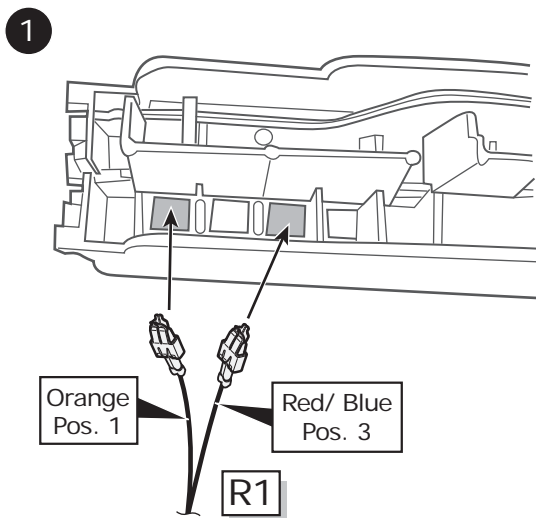

1

Orange
Pos. 1

Red/ Blue
Pos. 3

R1

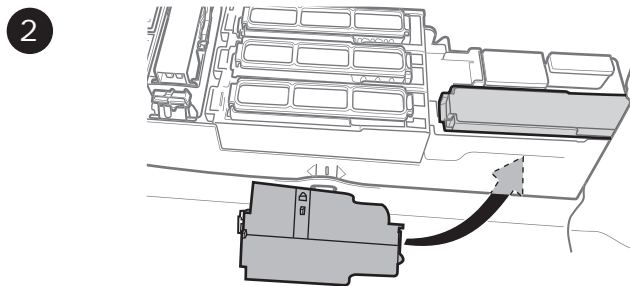

2

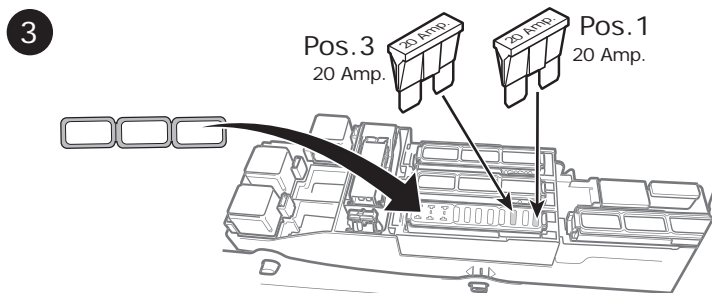

3

Pos. 3
20 Amp.

Pos. 1
20 Amp.

28

A6 Saloon/ A7 Sportback

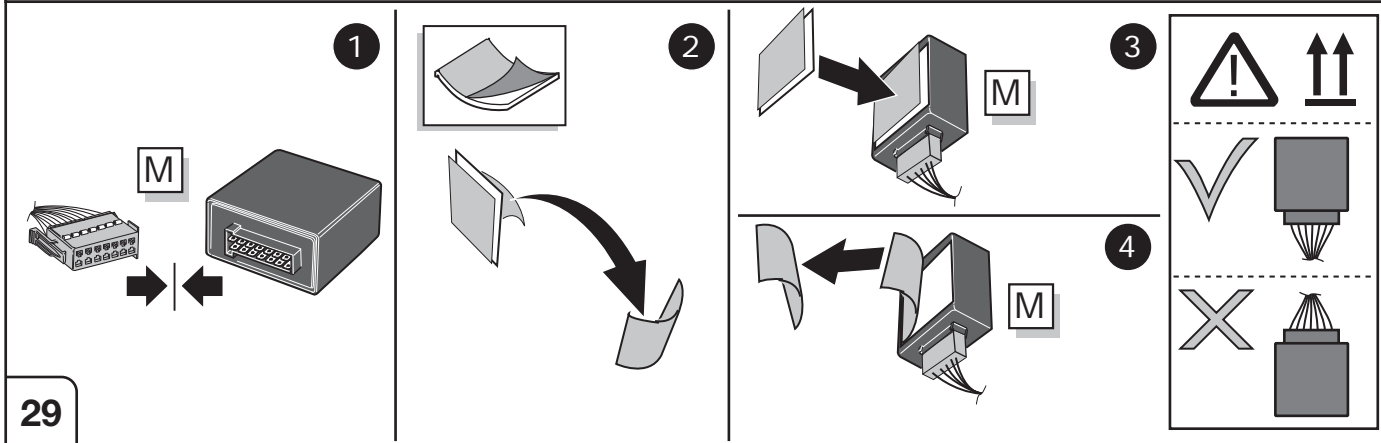

A6 Saloon/ A7 Sportback

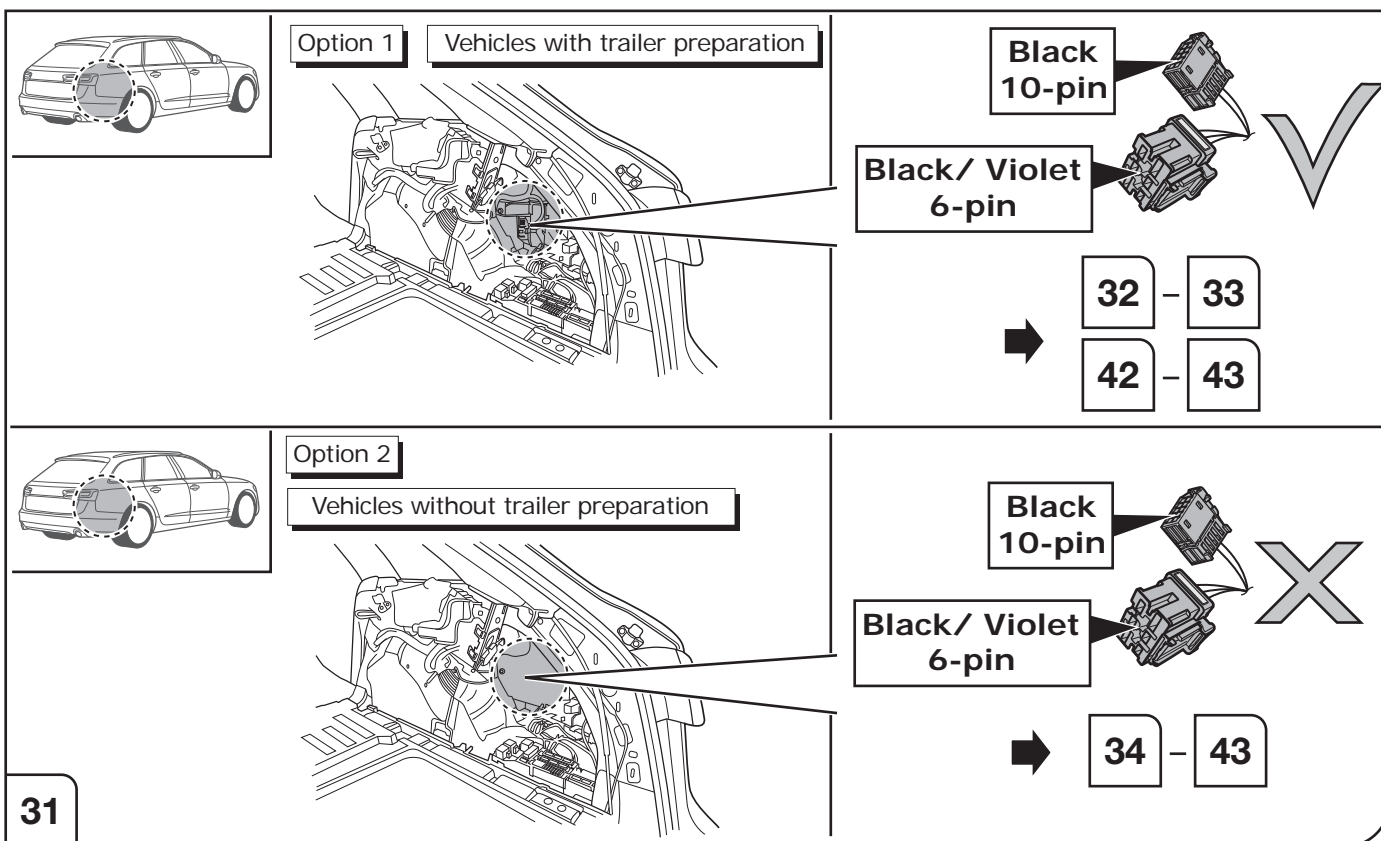
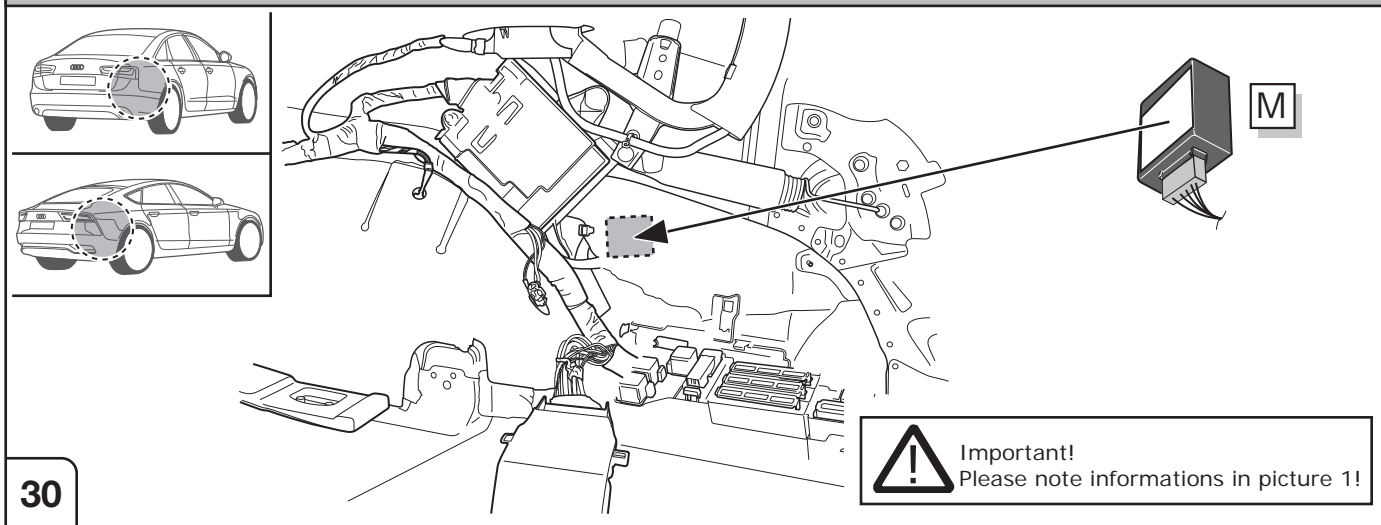

A6 Avant/ A6 Allroad Quatro

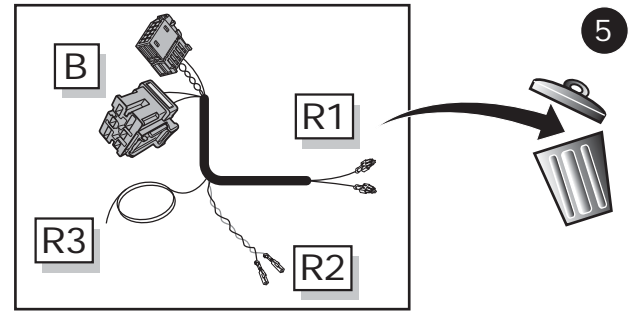
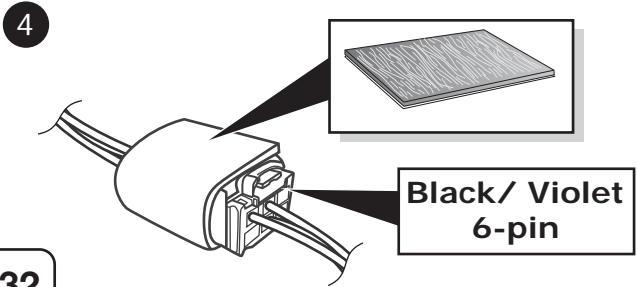
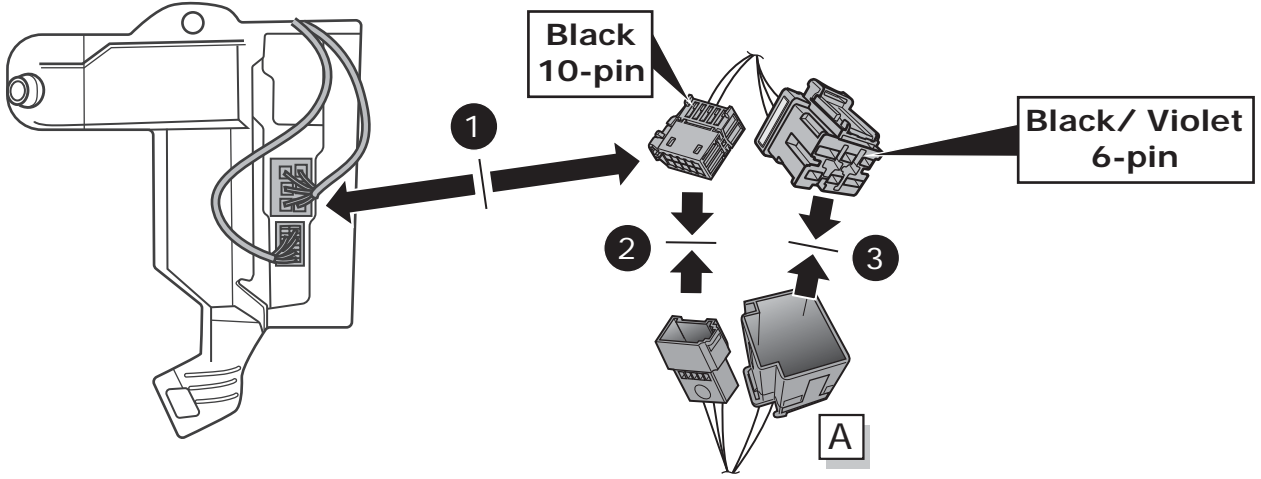

32

A6 Avant/ A6 Allroad Quatro

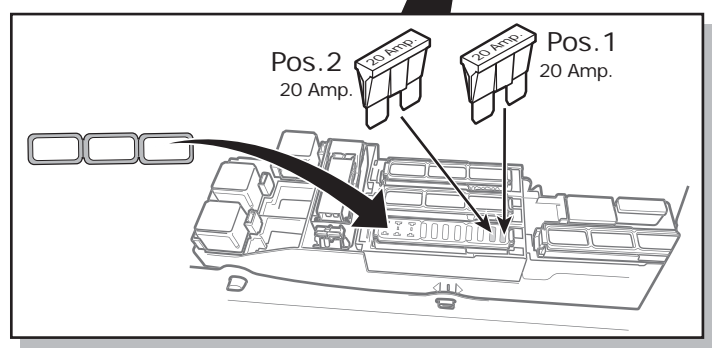
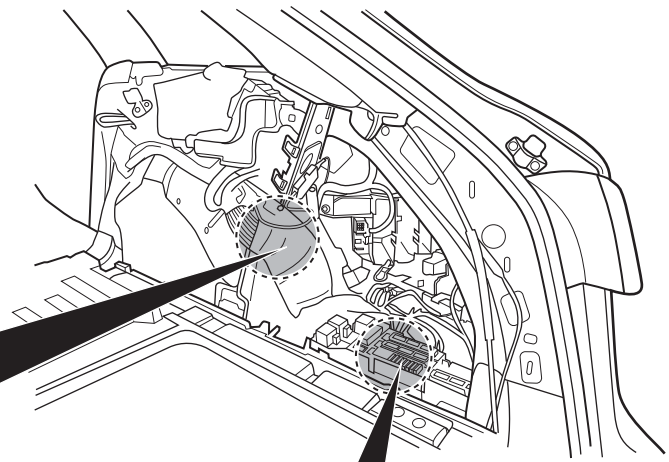
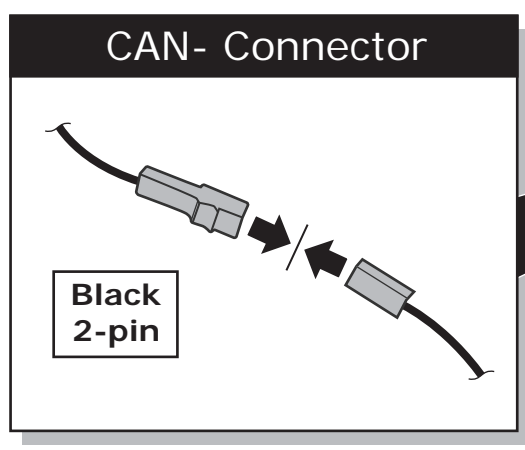
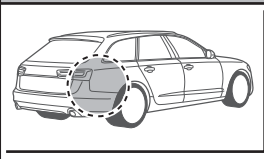

! Important!
Please note informations in picture 1!

33

A6 Avant/ A6 Allroad Quatro

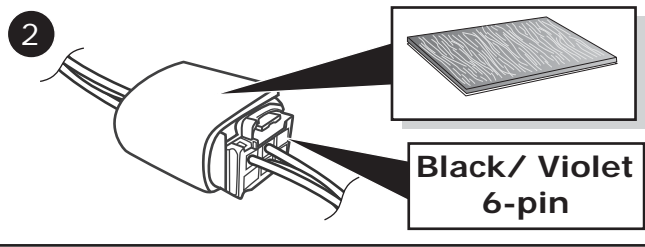
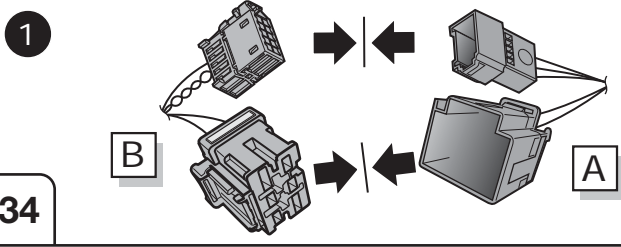

34

A6 Avant/ A6 Allroad Quatro

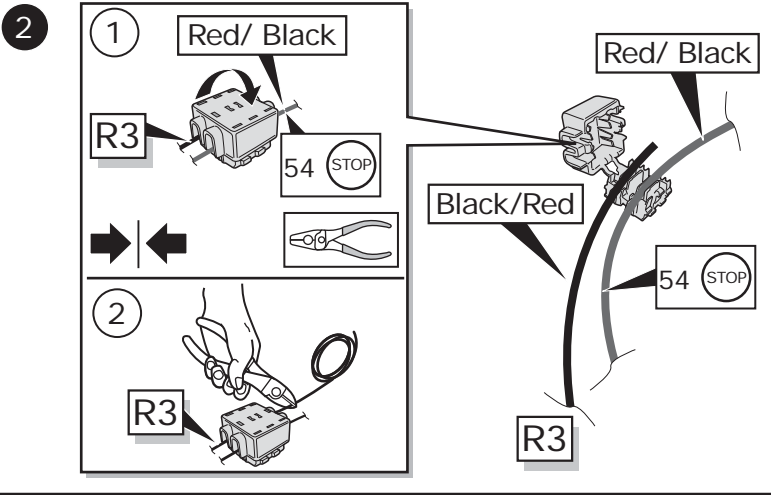
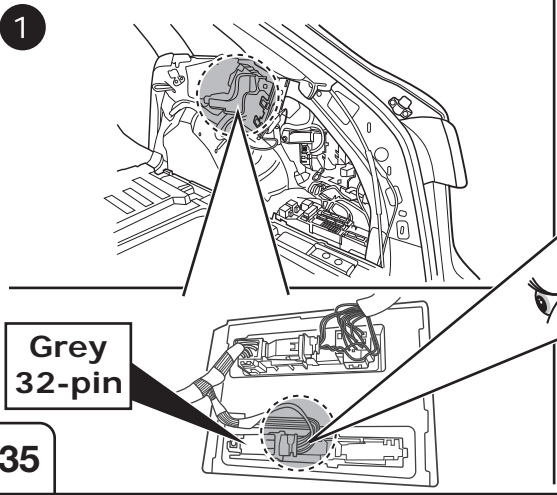

35

A6 Avant/ A6 Allroad Quatro

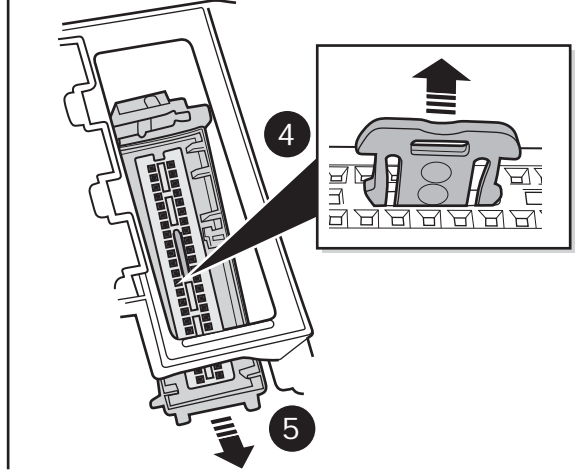
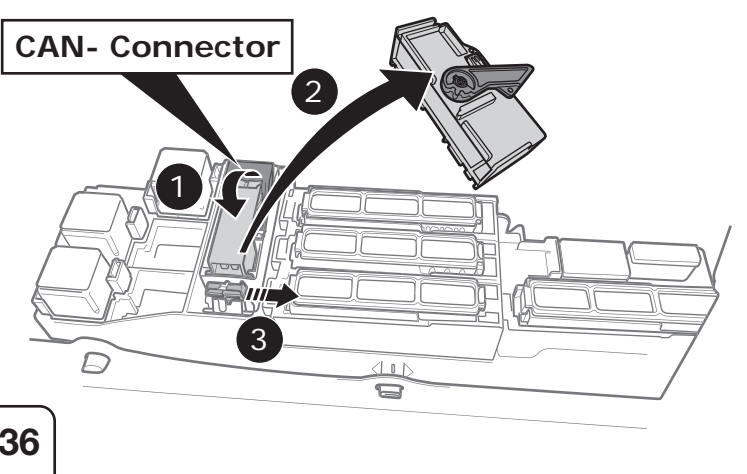

36

A6 Avant/ A6 Allroad Quatro

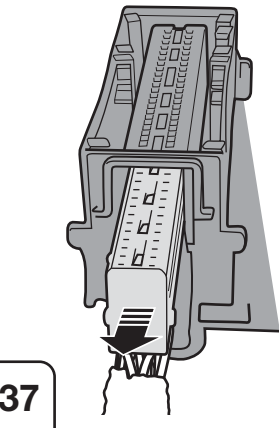

! Important!
Please note informations in picture 1!

Locate empty chambers in array 1-8

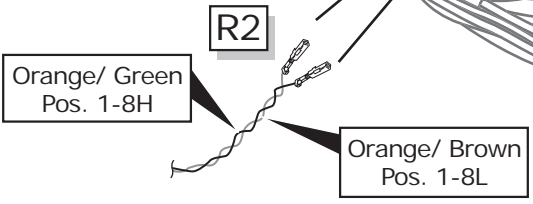

37

A6 Avant/ A6 Allroad Quattro

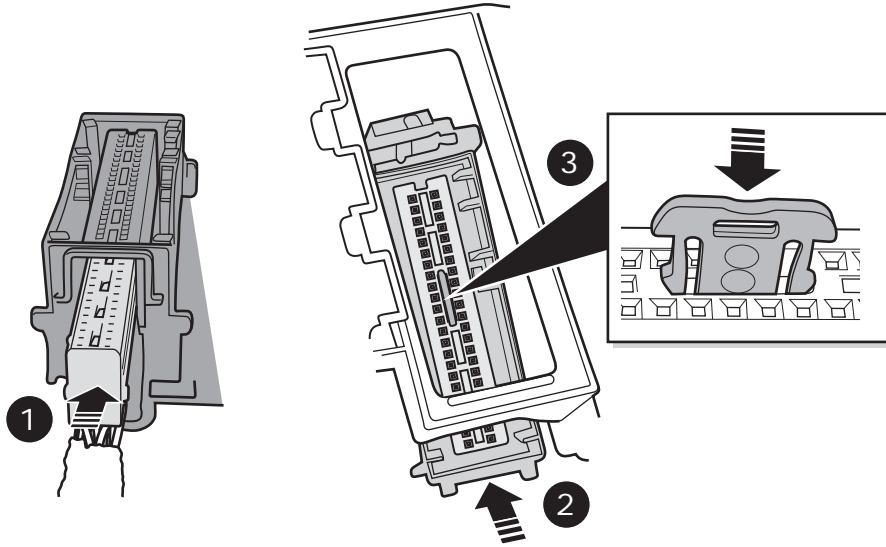

38

A6 Avant/ A6 Allroad Quattro

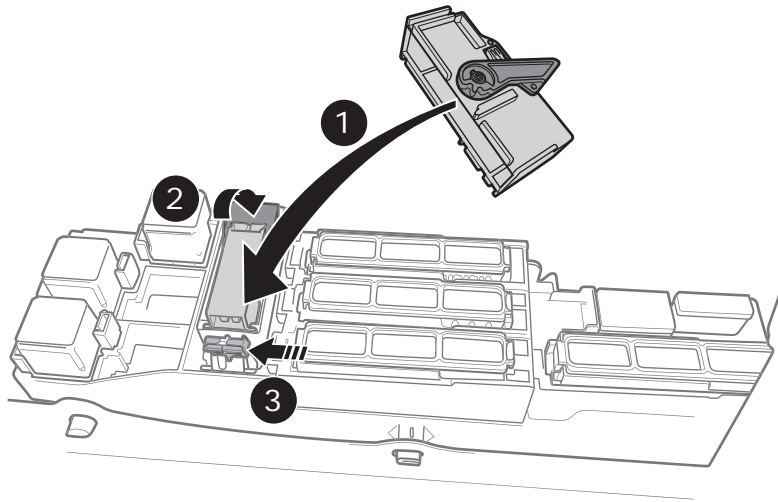

39

A6 Avant/ A6 Allroad Quattro

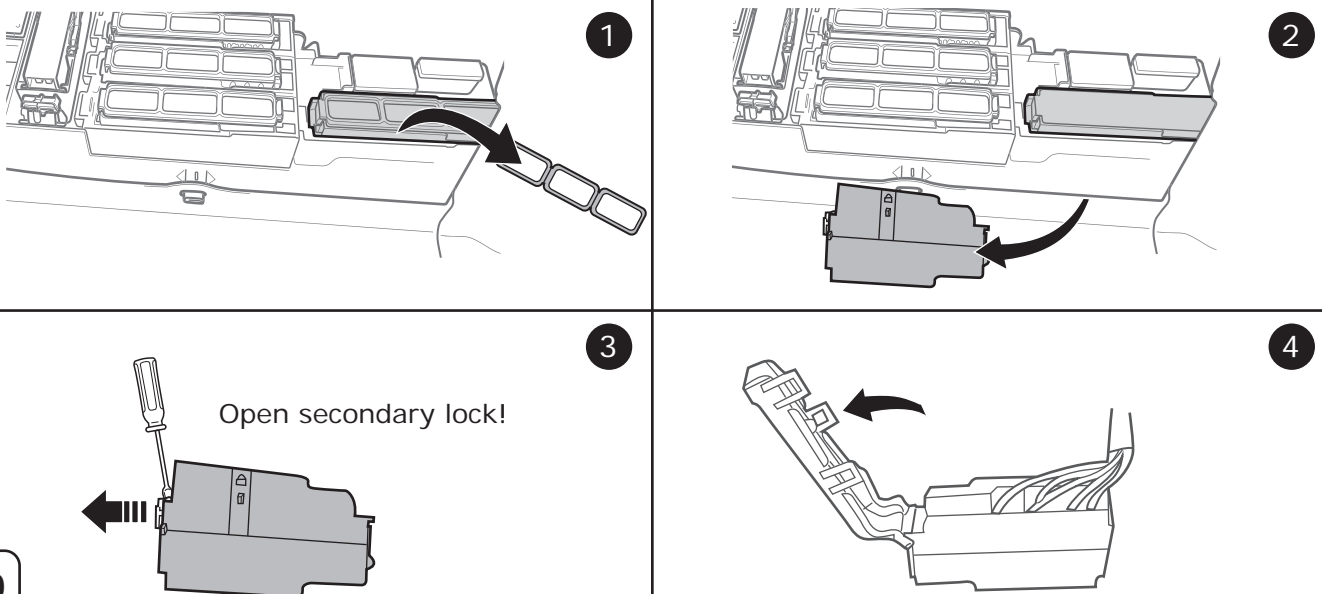

40

A6 Avant/ A6 Allroad Quatro

1

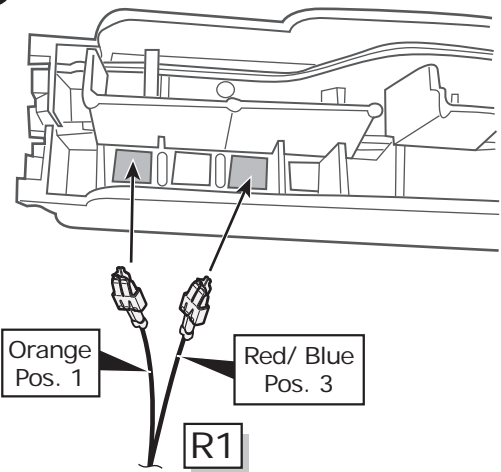

2

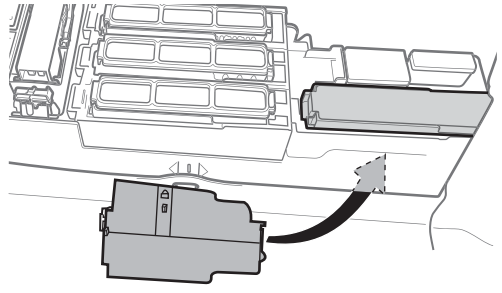

3

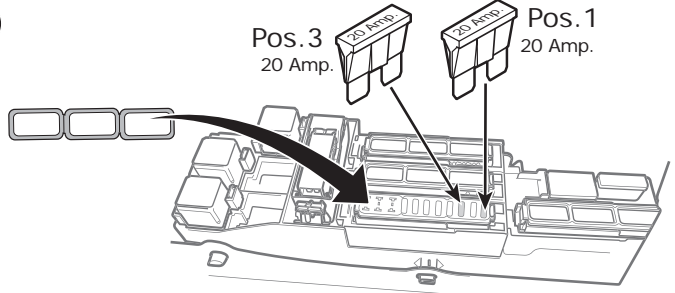

41

A6 Avant/ A6 Allroad Quatro

1

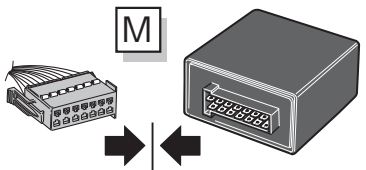

2

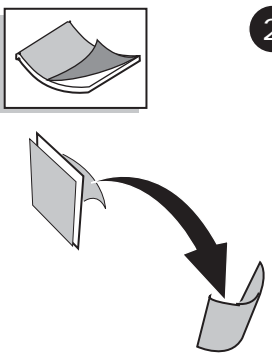

3

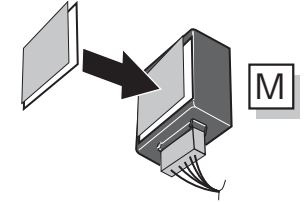

4

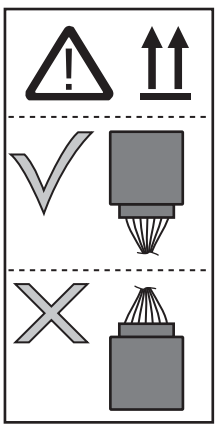
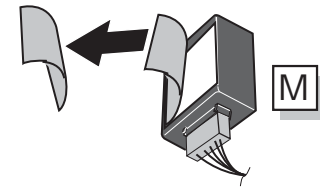

42

A6 Avant/ A6 Allroad Quatro

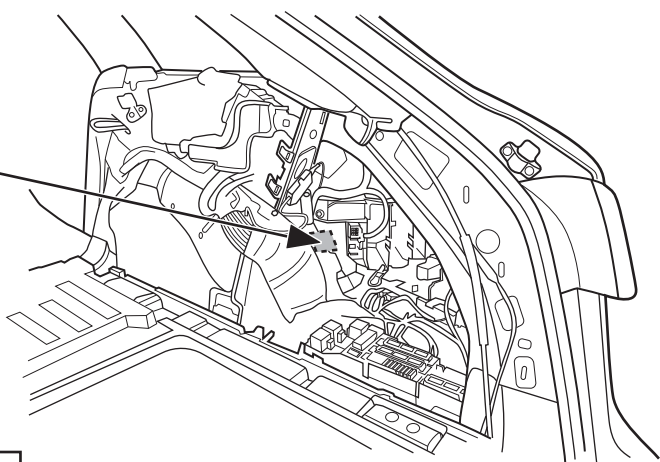
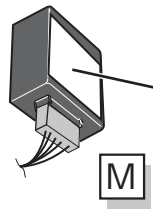
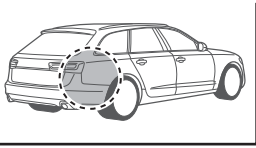

! Important!
Please note informations in picture 1!

43

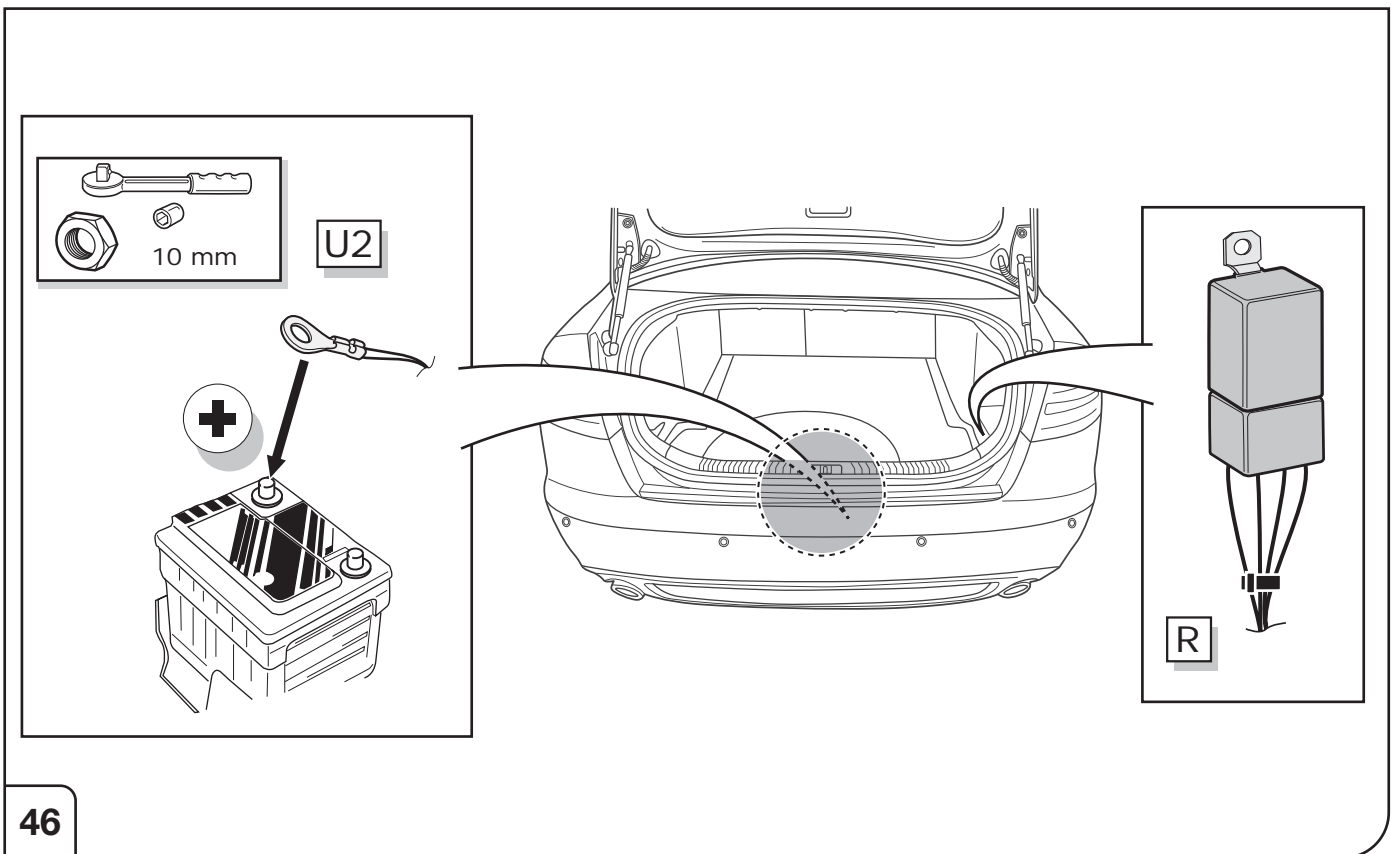
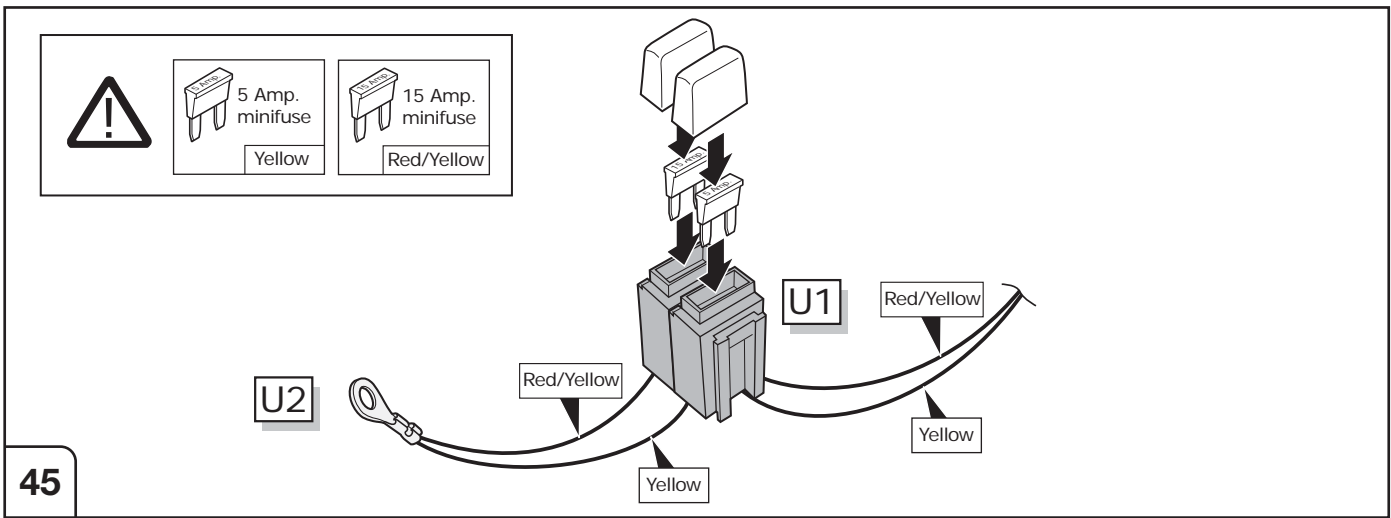
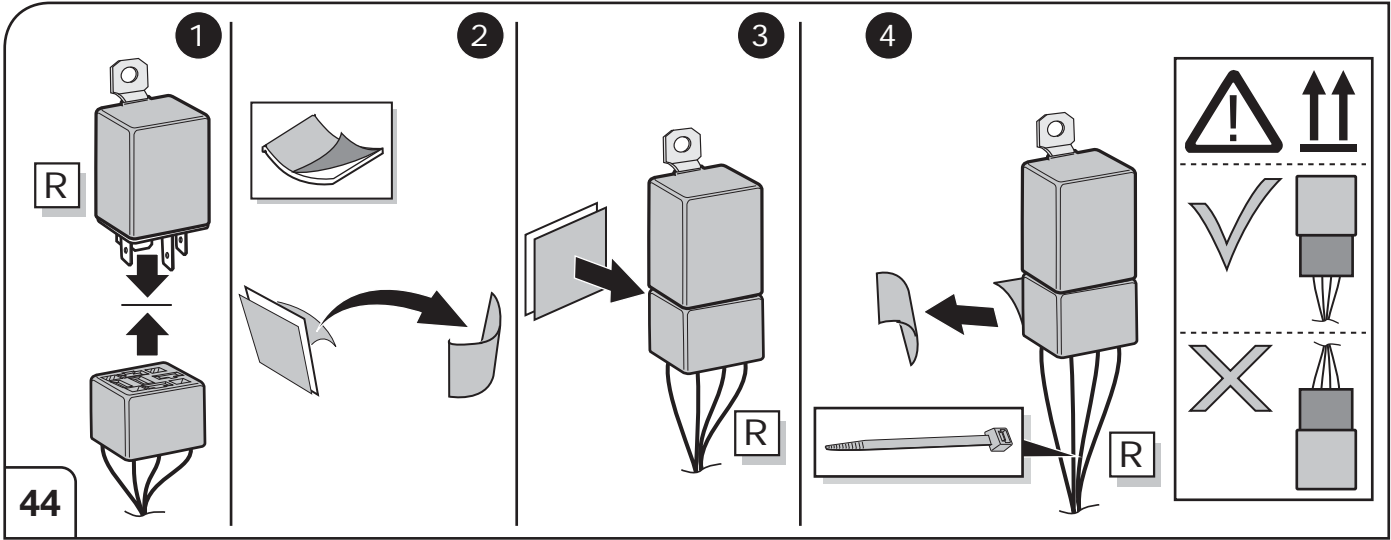

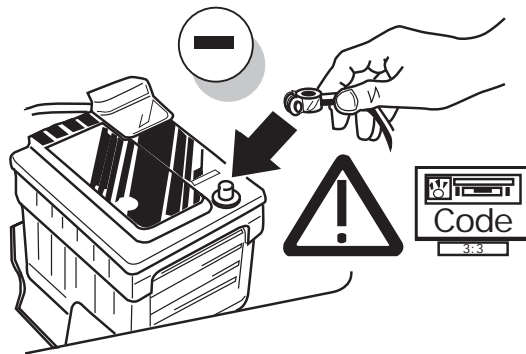

47

Optional

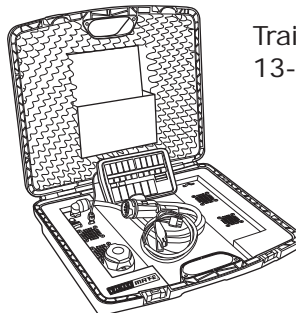

Trailer Simulator for 7- and 13-pin Sockets

48

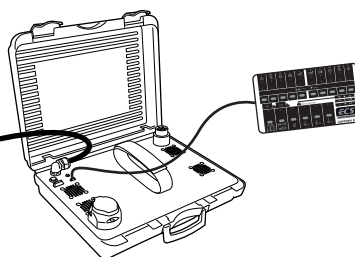
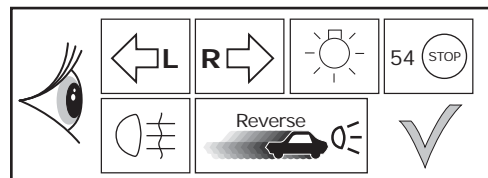
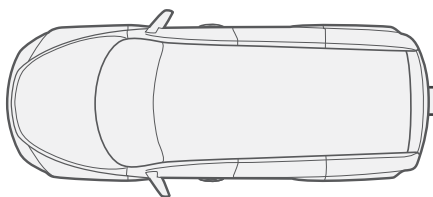

49

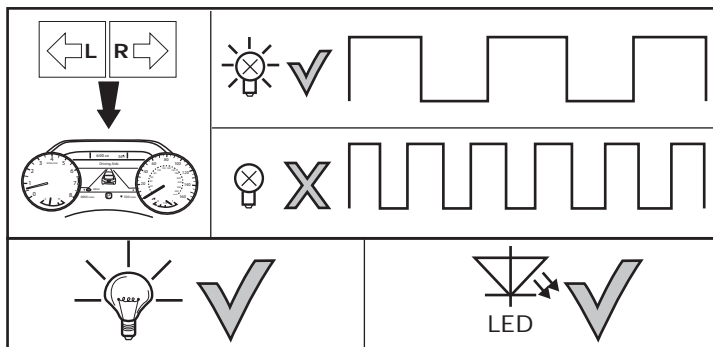
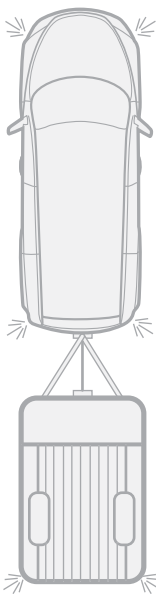

50

Optional

Adapter socket

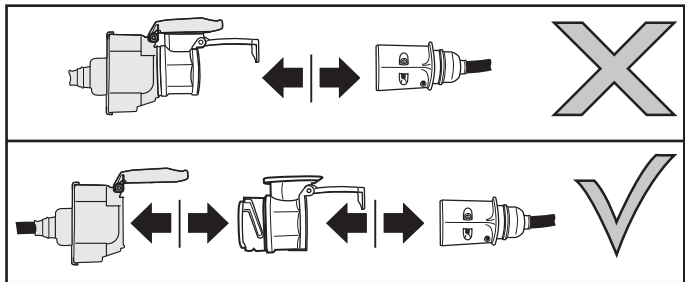
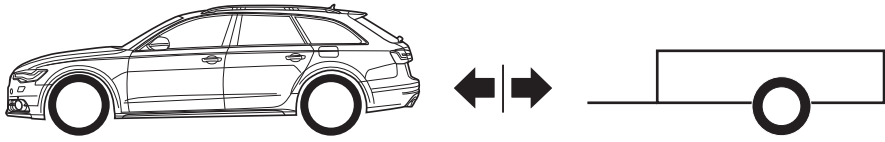
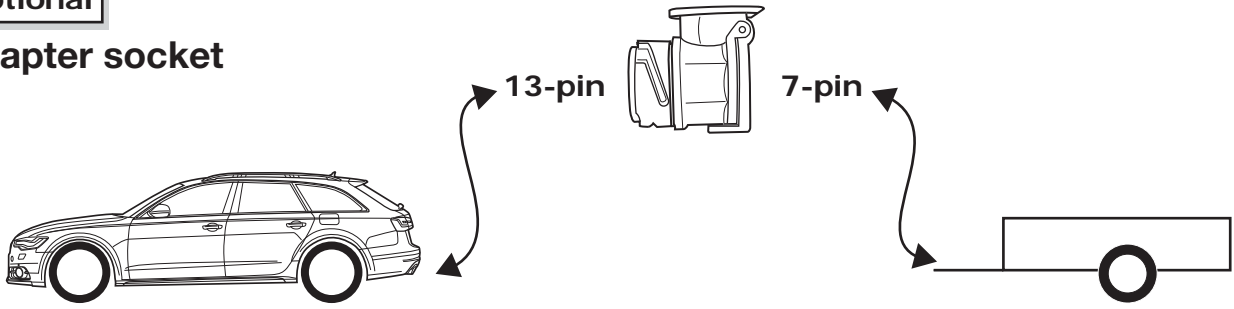

Set up trailer operation

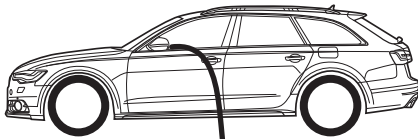

53

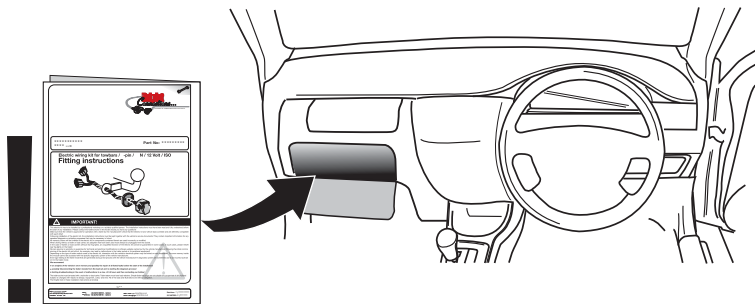

54

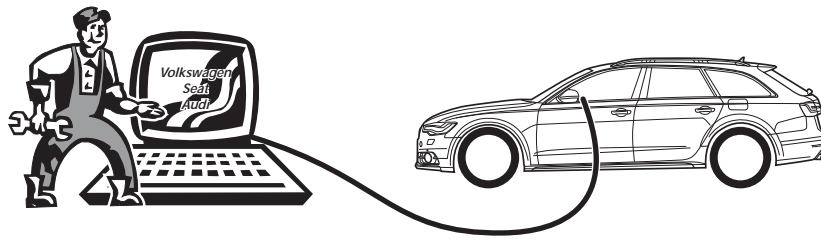

Coding with ODIS - Manually OFFLINE

Please note:

The procedure described below to configure and enable trailer mode settings, is based on a comprehensive number of control units that may be installed in the vehicle. Please check using your diagnostic equipment, what control units are actually installed.

NOTE! After connecting to ODIS, please ensure the "Trailer Function 69" controller has been enabled first

The following may be necessary in the further course of work:

→ **Coding ECE_09 (Electronic Central Electrics):**

Diagnosis
Networking plan
Controller self-diagnosis

Encode
Trailer connection device → installed
or: hitch_ecu → installed

→ **Coding ZKS_46 (Central module convenience system):**

Trailer monitoring → put on active
Trailer control unit → installed

→ **Encoding SWA_3C (Lane Change Assist)**

ECU for draw bar → with ECU for draw bar

→ **Encoding SCH_17 (Dash panel insert)**

Trailer → yes

→ **Encoding RFK_6C (reverse camera system)**

Equipment_ahk → installed

→ **Encoding STF_74 (chassis control system)**

Trailer → installed

→ **Encoding EPH_76 (PDC controller)**

Trailer → trailer device can be removed manually

→ **Encoding DIS_13 (controller distance control)**

Control module for
towing sens → installed

→ **Encoding FFF_A5 (front sensor system controller)**

AAG → coded

→ **Encoding HDE_6D (boot lid electronics controller)**

Trailer → installed

IMPORTANT note regarding encoding of control units for Trailer

The settings as listed above, form part of the vehicle configuration OFFLINE and therefore settings are saved locally in each respective control unit. It may occur that during certain ONLINE updates and repair work, the trailer mode settings may be overwritten and be reset back to 'as built'. In such cases, any relevant affected control unit will need to be re-configured again for trailer mode, using the latest coding information data for that particular vehicle.